

TWO PORT RADIATOR BALL VALVES

PN 10 ; 5...120 °C

HGT ... Eng.



- Body in nickel-plated brass and ball in chromed brass
- Female threaded input connection
- "Rafit" with male threaded tang to radiator output connection
- Teflon and Viton seals



1. APPLICATION

HGT valves are designed to control water flow in heating system. They are particularly suitable for replacing taps on radiators. They can be operated by hand or by rotary actuators model CDR.

Permitted fluids:

- hot water max. 120 °C,
- water with max. 50 % glycol.

2. MODELS

Code	DN body mm	Valve connection input	Valve connection output	Radiator tang	Kvs ⁽¹⁾ m ³ /h	Suitable actuator CDR ...
throughport		female	rafit	male		kPa ⁽²⁾ (bar) sec. ⁽³⁾
HGT 110	10	3/8"	1/2"	3/8"	5.4	600 (6) 60
HGT 115	15	1/2"	3/4"	1/2"	6	600 (6) 60
HGT 120	20	3/4"	1"	3/4"	11	600 (6) 60
HGT 125	25	1"	1"1/4"	1"	25.7	600 (6) 60
bypass						
HGT 210	10	3/8"	1/2"	3/8"	2.4	600 (6) 60
HGT 215	15	1/2"	3/4"	1/2"	2.6	600 (6) 60
HGT 220	20	3/4"	1"	3/4"	5	600 (6) 60
HGT 225	25	1"	1"1/4"	1"	11.7	600 (6) 60

(1) Kvs = flow coefficient : flow in m³/h with valve open and pressure drop of 100 kPa.

(2) kPa = maximum differential pressure Δp permitted by actuator. 100 kPa = 10 mWG = 1 bar

(3) sec. = time necessary for actuator to make complete valve run.

3. TYPICAL APPLICATION DIAGRAMS

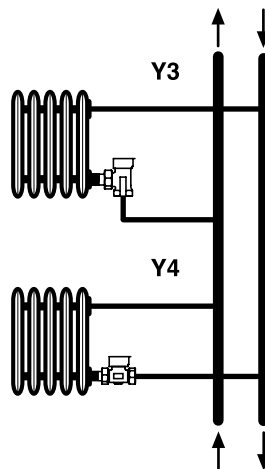
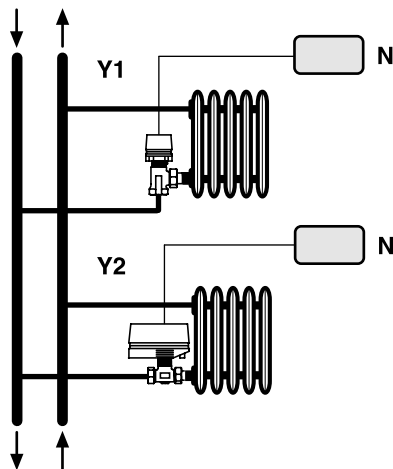

- N – Ambient controller
- Y1 – HGT 2.. valve with CDR... actuator
- Y2 – HGT 1.. valve with CDR... actuator
- Y3 – HGT 2.. valve with manual control
- Y4 – HGT 1.. valve with manual control

4. TECHNICAL DATA

Valve body
Spindle
Ball
Seals :
- ball
- spindle

nickel plated OT58 brass
stainless steel
hard chromed OT58 brass

PTFE (teflon)
viton O-Ring

Connections :
- input
- radiator
Nominal pressure
Fluid temperature
Run

female threaded
union with male threaded
1000 kPa (10 bar)
5...120 °C
90°

5. OVERALL DIMENSIONS

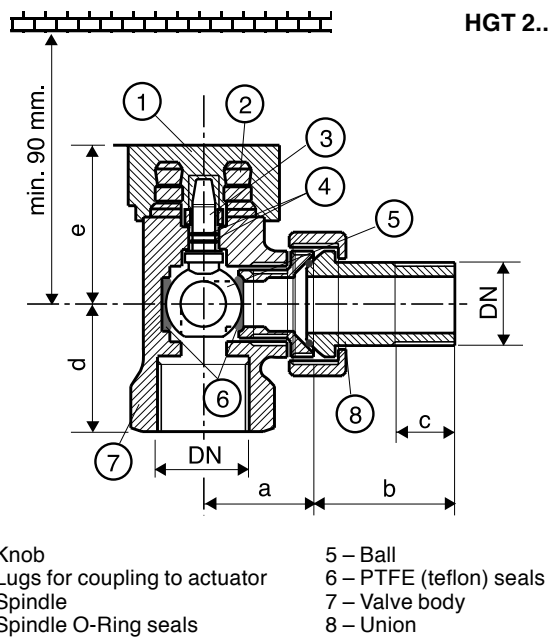
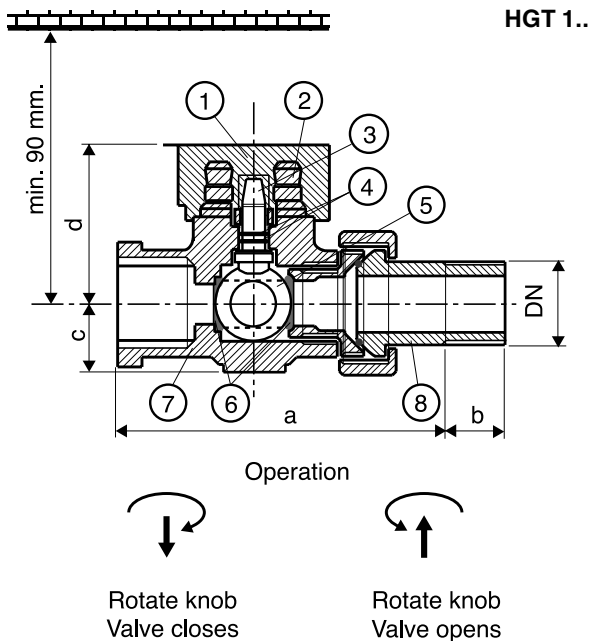

Model	DN inches	a mm	b mm	c mm	d mm
HGT 110	3/8"	71	9	16.5	36
HGT 115	1/2"	71	10	16.5	36
HGT 120	3/4"	74	12	20	41
HGT 125	1"	90	13	25	47

Model	DN inches	a mm	b mm	c mm	d mm	e mm
HGT 210	3/8"	25	24	9	26	36
HGT 215	1/2"	25.5	25.5	10	26	36
HGT 220	3/4"	26.5	28.5	12	52	41
HGT 225	1"	31	33	13	60	47

6. CONSTRUCTION

The valve body (5.7) is made in OT58 nickel-plated brass, the spindle (5.3) in stainless steel and the ball (5.5) in OT58 hard chromed brass.
 The ball is enclosed by two PTFE (teflon) seals (5.6) which ensure the total absence of let-by, while the spindle seal is ensured by two viton O-Rings (5.4).
 At the head of the valve there is a knob (5.1) for the manual control of the ball.

7. MOUNTING

7.1 Mounting of the valve

Before mounting the valve make sure that there isn't any extraneous matter in the pipework (remains of welding or threading). The pipework must not be subject to vibrations and must be perfectly aligned with the valve unions in order to avoid dangerous strains.
 The valve can be mounted in any position except with the spindle facing downwards.
 Leave enough space on the spindle side for the mounting of actuator (see section 5).

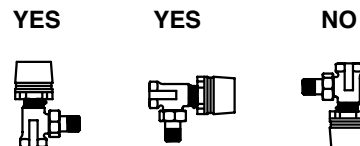

7.2 Installing the actuator on the valve

Set the valve in open position manually, pull out the hand grip from the valve and then insert and push down the CDR actuator (factory setting: "Open" position).

8. OPERATION

The valve operates with a 90° rotary movement.
 When the valve is open there is full bore with very low pressure drop, whereas when is closed the seals prevent any let-by.
 The valve can be operate by hand, using the hand grip, or by the CDR actuator.
 A mark on the valve spindle, also visible when the actuator is installed, indicates the position of the valve.

MC 27.07.00 Rev.: MZ 10.02.05



Head Office & Sales
 Via San G.B. De La Salle, 4/a Tel. +39 022722121
 20132 - Milan Fax +39 022593645

Reg. Off. Central & Southern
 Via S. Longanesi, 14 Tel. +39 065573330
 00146 - Roma Fax +39 065566517

Orders and Shipping
 Via Gen. Treboldi, 190/192 Tel. +39 0364773200
 25048 - Edolo (BS) Tel. +39 0364773202
 Fax +39 0364770016

E-mail: info@coster.info Web: www.coster.info



D 33115