

# REVERSIBLE 90° ROTARY ACTUATOR FOR VERY LARGE VALVES

## CVF Eng.

- Power supply: 230 V ~ or 24 V~
- Three-wire electric control (common, opens, closes)
- Rotation angle : 90°
- Run times: 450 – 150 seconds
- Two end-of-run microswitches
- Release mechanism for manual control
- Protection : IP 55



### 1. APPLICATION

CVF actuators are designed for the operation of Coster rotary valves:

- VSF-VFF mixing valves sizes DN 100 - 125 - 150,
- 2 S ball sizes DN 80 - 100,
- YDG ball sizes 3" - 4".

Using AVF linkage kits, CVF actuators can be mounted on other makes of mixing valves in the DN 125 - 150 size range.

### 2. MODELS

Model	Power supply V ~ (VA)	Time s	Nominal torque kg/cm (Nm)	Starting torque kg/cm (Nm)	Valves DN		
					Mixing VSF-VFF	Ball 2S	Ball YDG
<b>CVF 458</b>	230 (6)	450	1,200 (120)	1,200 (120)	100...150	80...100	3"...4"
<b>CVF 454</b>	24 (6)	450	1,200 (120)	1,200 (120)	100...150	80...100	3"...4"
<b>CVF 158</b>	230 (7)	150	1,000 (100)	1,000 (100)	100...150	80...100	3"...4"
<b>CVF 154</b>	24 (7)	150	1,000 (100)	1,000 (100)	100...150	80...100	3"...4"

### 3. ACCESSORIES

Model	Description
<b>AVF 171</b>	Linkage kit for Coster VFF DN 100 valves.
<b>AVF 172</b>	Linkage kit for valves for following makes of valves : Buche, Honeywell/Mut 2, Landis & Gyr/Lazzari, Jucker, Zentra, Stark.

### 4. TECHNICAL DATA

Power supply :			
– CVF 458-158	230 V ~	Nominal torque :	
– CVF 454-154	24 V ~	– CVF 458-454	1,200 kg/cm (120 Nm)
Frequency	50...60 Hz	– CVF 158-154	1,000 kg/cm (100 Nm)
Consumption :		Starting torque :	
– CVF 458-454	6 VA	– CVF 458-454	1,200 kg/cm (120 Nm)
– CVF 158-154	7 VA	– CVF 158-154	1,000 kg/cm (100 Nm)
Rotation angle	fixed at 90°	Valve fluid temperature	0...120 °C
Auxiliary microswitches :		Ambient temperature :	
– maximum switching voltage	250 V ~	– Operating	0...45 °C
– maximum switching current	5 (1) A	– Storage	-20...+60 °C
Run times :		Protection	IP 55
– CVF 458-454	450 seconds	Weight	4.300 kg
– CVF 158-154	150 seconds		

## 5. OPERATION

CVF actuators can be controlled by an On-Off or modulating device (e.g. thermostat, manual switch, modulating controller) provided it has an SPDT switch. The three-wire control (common, opens, close) powers a small, reversible, synchronous electric motor with double windings which is housed together with a speed-reduction gear box (6.1). The output from the first-stage gear box is transmitted to a second speed-reduction gear box (6.2) and from this the rotary movement is transmitted to the valve spindle (6.4).

The valve can also be operated by hand, as follows: by loosening the two knurled bolts (6.7) the housing of the first speed-reduction gear box can be uncoupled from the second gear box (6.1) by sliding it along the two pivots (6.8). The valve can be positioned manually by means of the handwheel (6.3).

The actuator run is 90° and is limited electrically by two microswitches (7.4) operated by a cam (7.2); these switches, together with the terminal block for the electrical connections, are housed in a waterproof container (6.6).

The end-of-run microswitches can be adjusted to a limited extent in order to permit exceeding slightly the 90° run in order to improve, if necessary, the closure of the valve. To adjust one of the end-of-run microswitches, loosen the securing bolt (7.5) of the relative mobile housing (7.3); using a screwdriver, rotate the eccentric (7.6) clockwise for the right end-of-run and anticlockwise for the left end-of-run. Having obtained the desired adjustment, tighten the securing bolts (7.5).

All the models are supplied with two auxiliary microswitches with single contacts located above the end-of-run microswitches (7.4) and operated by the same cam (7.2).

## 6. OVERALL DIMENSIONS

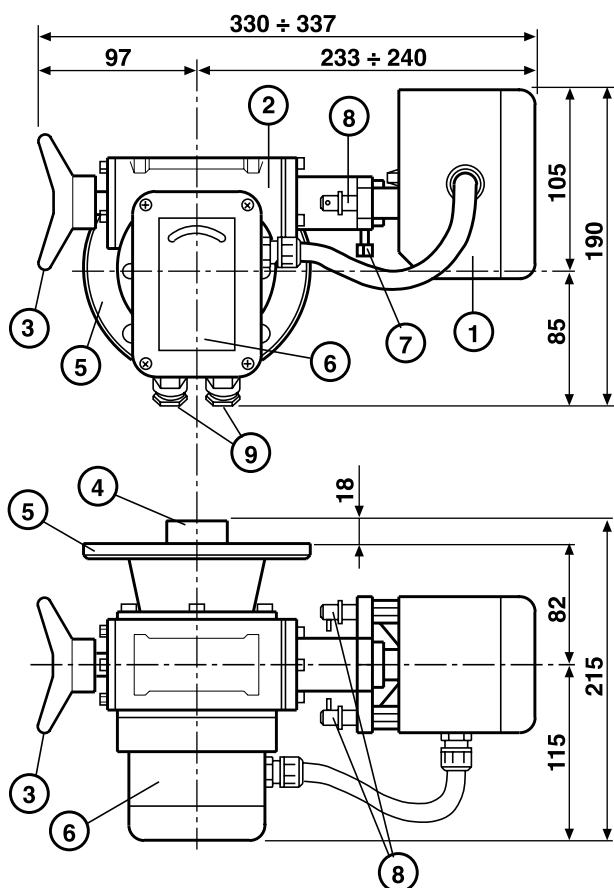

- 1 – Housing for electric motor
- 2 – Speed reduction gear box
- 3 – Handwheel for manual operation
- 4 – Valve transmission spindle
- 5 – Valve linkage flange
- 6 – Housing for terminal block for electrical connections and end-of-run microswitches
- 7 – Bolts for manual release
- 8 – Pivots for de-coupling electric motor
- 9 – PG 11 glands for electric cables

## 7. MICROSWITCHES & TERMINAL BLOCK

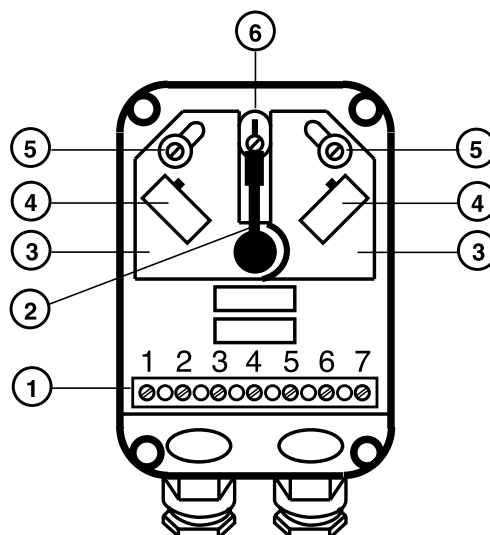

- 1 – Terminal block for electrical connections
- 2 – Cam
- 3 – Adjustable plate for microswitches
- 4 – End-of-run microswitches and auxiliary microswitches
- 5 – Fixing bolts for adjustable plate
- 6 – Eccentric for adjusting position of microswitches

**8. CONSTRUCTION**

The base consists of a worm-type speed reduction mechanism (6.2).  
 The casing is in diecast aluminium and the internal mechanical parts in tempered steel.  
 On the front of the speed reduction mechanism is mounted the casing in nylon/glass fibre with polycarbonate cover, in which are housed the microswitches, the cam and the terminal block for the electrical connections (6.6).  
 At the rear is the valve linkage flange (6.5) and the valve transmission shaft (6.4), positioned to facilitate mounting the actuator on the valve.  
 Crosswise is mounted the housing for the electric actuator (6.1) with its release mechanism (6.7 and 6.8) and, on the other side, the handwheel for manual positioning of the valve (6.3).

**9. MOUNTING THE HANDWHEEL**

The handwheel for the manual control of the actuator is supplied separately. Insert it on the part of the shaft which protrudes from the other side of the electric actuator so that the fixing bolt is perpendicular to the cavity on the shaft. Tighten carefully using small movements of the handwheel to ensure that the bolt enters in the cavity.

**10. MOUNTING ACTUATOR ON VALVE**

- **On Coster valves (mixing VSF-VFF DN 125-150, 2S ball, YDG ball) :**
  - Position the valve spindle (11.1) so that the internal rotor is halfway between the closed and open positions..
  - Loosen the knurled bolts in the manual release (6.7), move back the electric actuator (6.1) and position the transmission shaft (6.4) to half run using the handwheel (6.3).
  - Mount the actuator so that its shaft couples directly with the valve spindle and then secure the actuator to the valve with the four bolts (11.3) supplied with the actuator.
  - By hand, make a couple of complete valve runs, bring the electric actuator to the automatic operating position and then tighten up the knurled bolts on the manual release.
  
- **On Coster mixing valves VSF-VFF DN100 (with AVF171) or non-Coster DN125-150 (with AVF 172) :**
  - Position the valve spindle (11.1) so that the internal rotor is halfway between the closed and open positions..
  - Loosen the knurled bolts in the manual release (6.7), move back the electric actuator (6.1) and position the transmission shaft (6.4) to half run using the handwheel (6.3).
  - Fix the linkage plate (11.4) to the valve using the bolts (11.5) supplied with the AVF connections..
  - Mount the spacing collars (11.7) on the coupling plate..
  - Insert the coupling joint (11.6) on the valve spindle
  - Mount the actuator so that its shaft couples with the milling on the coupling joint and secure it to the spacing collars with two bolts (11.3) supplied with the actuator.
  - By hand, make a couple of complete valve runs, bring the electric actuator to the automatic operating position and then tighten up the knurled bolts on the manual release.

**11. MOUNTING**

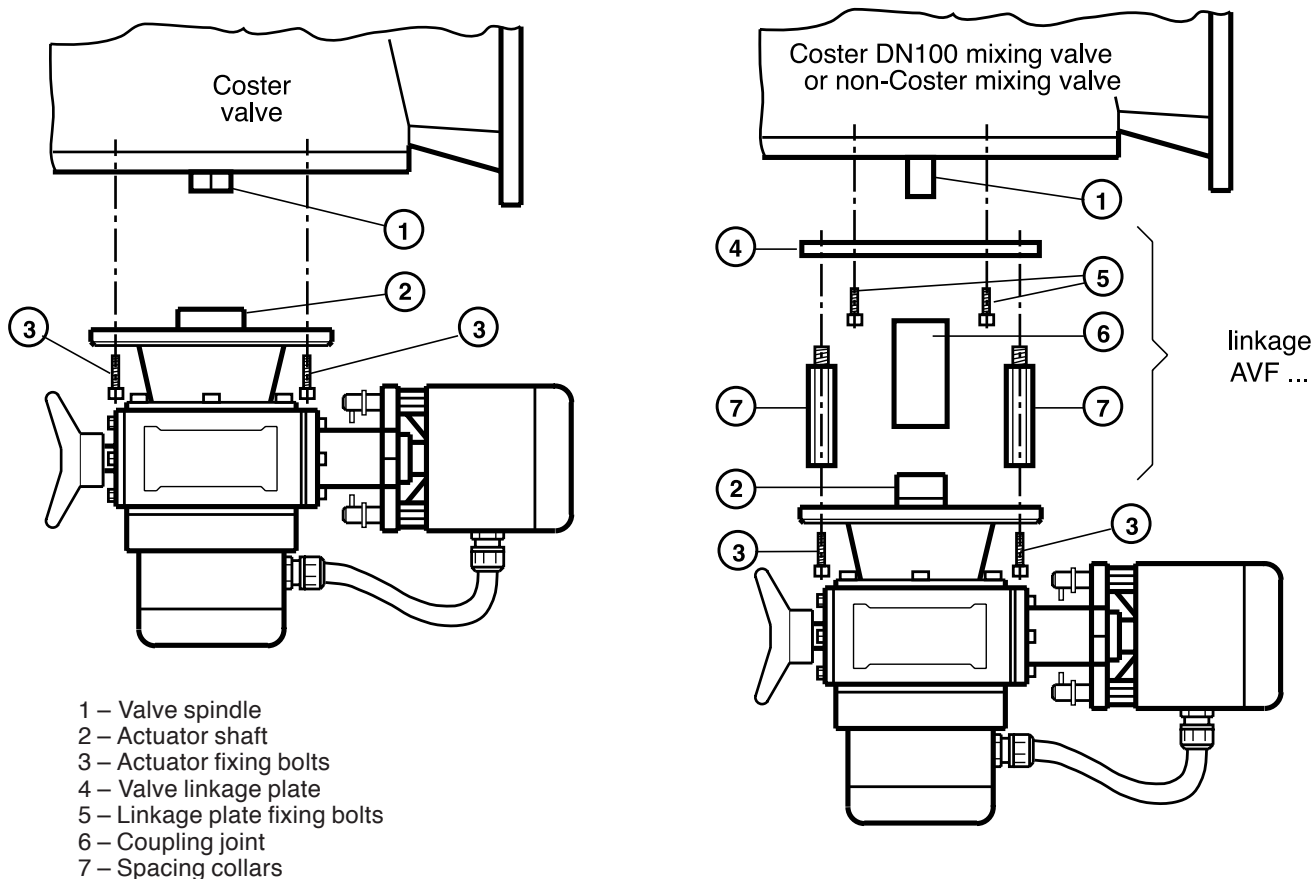

## 12. ELECTRIC WIRING

To make the electrical connections proceed as follows::

- Remove the protective cover from the terminal block (6.6) by loosening the four securing bolts
- Introduce the electric cables into the actuator through the PG 11 cable glands provided (6.9),
- Make the connections according to the diagram (13) and in respect of the safety regulations in force, using 1.5 mm<sup>2</sup> cables,
- Replace the protective cover, ensuring that the gasket is correctly positioned, and then tighten up the four securing bolts.

## 13. WIRING DIAGRAM

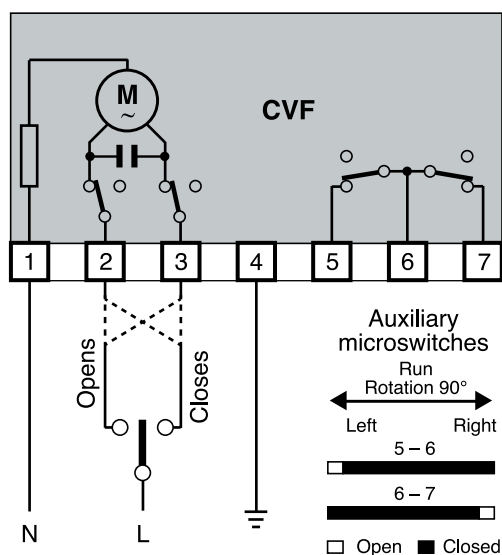

LB 11.93 ; Rev. : MZ 25.05.04, MZ 06.09.04



CONTROLLI  
TEMPERATURA  
ENERGIA

COSTER TECNOLOGIE ELETTRONICHE S.p.A.  
Sede Legale: 25048 Edolo (BS) - Via Gen. Treboldi, 190

### Head Office & Sales

Via San G.B. De La Salle, 4/a      Tel. +39 022722121  
20132 - Milan                      Fax +39 022593645

### Reg. Off. Central & Southern

Via S. Longanesi, 14              Tel. +39 065573330  
00146 - Roma                      Fax +39 065566517

### Orders and Shipping

Via Gen. Treboldi, 190/192      Tel. +39 0364773200  
25048 - Edolo (BS)              Tel. +39 0364773202  
Fax +39 0364770016

E-mail: [info@coster.info](mailto:info@coster.info)      Web: [www.coster.info](http://www.coster.info)

ISO 9001:2000



THE INTERNATIONAL CERTIFICATION NETWORK  
Registration Number: IT - 34674  
CSQ - Certificate N. 9115.COEE

D 33044



We reserve the right to make changes without notice