

# REVERSIBLE 90° ROTARY ACTUATORS

## CVC Eng.



- Power supply: 230 V ~ or 24 V ~
- Three-wire electric control (common, opens, closes) or two-wire (CVC.../S2)
- Rotation angle: : 90°
- Run times: 180 – 90 – 30 – 15 seconds
- Two auxiliary end-of-run SPDT miniature switches (except for CVC.../T)
- Manual release mechanism (on request)
- IP 55 protection

### 1. APPLICATION

CVC actuators are designed to operate Coster rotary valves :

- mixing VSG, VSF, VFG, VFF up to DN 50,
- ball XDG, XLG, YDG up to 1"1/4,
- butterfly shut-off 2F (DN see 2.MODELS).

Using AVA and AVS linkage kits CVC actuators can be used to operate mixing valves of other makes.

### 2. MODELS

Model	Power supply V ~ (VA)	Run time s	Nominal torque kg/cm (Nm)	Starting torque kg/cm (Nm)	Valves (up to DN)		
					Mixing VSG-VSF-VFG-VFF	Butterfly 2F	Ball XDG-XLG-YDG
<b>CVC 188</b>	230 (2.5)	180	60 (6)	90 (9)	50	65	1"1/4
<b>CVC 184</b>	24 (2.5)	180	60 (6)	90 (9)	50	65	1"1/4
<b>CVC 098</b>	230 (4.5)	90	60 (6)	90 (9)	50	65	1"1/4
<b>CVC 094</b>	24 (4.5)	90	60 (6)	90 (9)	50	65	1"1/4
<b>CVC 038</b>	230 (5.0)	30	60 (6)	90 (9)	50	65	1"1/4
<b>CVC 034</b>	24 (5.0)	30	60 (6)	90 (9)	50	65	1"1/4
<b>CVC 018</b>	230 (7.0)	15	60 (6)	90 (9)	50	–	1"1/4
<b>CVC 014</b>	24 (7.0)	15	60 (6)	90 (9)	50	–	1"1/4

### 3. SPECIAL MODELS

Model	Description
<b>CVC.../T</b>	Supplied with 6W heater for use in plants with chilled water (without auxiliary miniature switches).
<b>CVC.../T/S1</b>	Supplied with 6W heater for use in plants with chilled water (with auxiliary miniature switches).
<b>CVC.../S2</b>	Supplied with relay to adapt it for On-Off two-wire control (only for 230 V ~ models).

### 4. ACCESSORIES

Model	Description
<b>SMP 750</b>	Manual release for mixing valves (VSG, VSF, VFG, VFF), butterfly (2F) and ball (XDG and XLG).
<b>SMP 760</b>	
<b>AVA 101</b>	Universal linkage kit for valves : Buche, Controlli, Honeywell, Mut, Landis & Gyr, Lazzari, Stark, Zentra.
<b>AVS 102</b>	Universal linkage kit for other makes of valve (universal linkage plate without holes).

### 5. TECHNICAL DATA

Power supply (see 2.Models)	23V ~ , 24 V ~	Materials :	
Frequency	50...60 Hz	– base	Nylon + glass wool
Consumption (see 2.Models)	2.5...7 VA (+6W for /T and /T/S1)	– cover	polycarbonate
Rotation angle	fixed at 90°	Valve fluid temperature	0...120 °C
Run times (see 2.Models)	15...180 seconds	– only for CVC.../T and /T/S1	–15...120 °C
Nominal torque	60 kg/cm (6 Nm)	Ambient temperature :	
Starting torque	90 kg/cm (9 Nm)	– operating	0...45 °C
Auxiliary miniature switches :		– storage	– 20...+60 °C
– maximum switching voltage	250 V ~	Protection	IP 55
– maximum switching current	5 (1) A	Weight	0.620 kg

## 6. OPERATION

CVC can be controlled by an On-Off or modulating device (e.g. thermostat, switch, modulating controller) provided with an SPDT output switch. Only model CVC...S2, provided with an internal relay, can be controlled by a device fitted with a simple open-closed switch.

The small electric motor transmits the rotary movement to a mechanical reduction unit which determines the rotation speed of the shaft and, accordingly, the run time of the actuator.

The actuator has a rotary movement with a working angle of 90°, limited by two miniature switches (9.6) operated by an end-of run cam (9.7).

It is provided with two voltage-free SPDT auxiliary miniature switches, positioned near the extreme closure and opening points.

Using the SMP... manual release it is possible to release the actuator from the valve thereby permitting manual adjustment.

## 7. CONSTRUCTION

The base of the CVC (9.1) is made of Nylon 66 whilst the cover is in semi-transparent polycarbonate to permit checking the position of the cam. These two features, together with the appropriate gaskets, ensure the IP 55 level of protection.

Two PG 11 (9.4) screwed holes in the lower part of the base permit the mounting an entry gland for the electric cables.

When the protective cover is removed the connections can be made to the terminal block (9.5).

The coupling for the valve is in the rear part of the base and permits rapid mounting:

- for ball valves, using only the two threaded pins (10.5).
- for mixing and butterfly valves, the two threaded pins plus a fastening tongue (10.6) supplied with the actuator.

## 8. INSTALLATION

### • On Coster ball valves XDG2, XDG3, XLG3 and YDG2 :

– Loosen the two screws (9.3), withdraw the two threaded pins (10.5) and screw them into the valve linkage support (10.1).

– Position the valve spindle (10.2) so that the position of the milling coincides with that on the actuator shaft (10.4).

– Mount the actuator so that the pins fit into their housings and so that the actuator shaft fits into the milling on the valve spindle. Then secure it by tightening the two screws (9.3).

If the manual release SMP... is used, place this between the valve shaft and the actuator spindle.

Then use the two spacing collars (10.13) supplied with the SMP..., instead of the threaded pins (10.5).

Using the manual control, make a couple of complete valve runs to check that the movement is uniform.

### • On Coster mixing valves VSG-VSF-VFG-VFF or Coster butterfly valves 2F :

– Loosen the two screws (9.3), withdraw the two threaded pins (10.5) and screw them into the valve supports (10.3).

– Mount the Coster valve linkage (10.6) on the valve spindle and position it so that the milling corresponds with that on the actuator shaft (10.7).

– Mount the actuator so that the pins fit into their housings and so that the actuator shaft fits into the milling on the valve spindle. Then secure it by tightening the two securing screws (9.3).

If the manual release SMP... is used, place this between the valve spindle and the actuator shaft.

Then use the two spacing collars (10.13) supplied with the SMP..., instead of the threaded pins (10.5).

Using the manual control, make a couple of complete valve runs to check that the movement is uniform.

### • On non-Coster mixing valves (use AVA 101 or AVS 102) :

– Loosen the two screws (9.3), withdraw the two threaded pins (10.5) and screw them into the valve linkage support (10.3).

– After having checked the correct position of the valve sector or butterfly mount the linkage (10.11) on the spindle so that the milling corresponds with that on the actuator spindle (10.4).

– Fix the linkage bracket to the valve using the screws (10.8) supplied with the AVA 101 or AVS 102 linkage.

– Mount the actuator so that the pins fit into their housings and so that the actuator shaft fits into the milling on the valve spindle. Then secure it by tightening the two screws (9.3).

If necessary, loosen the securing screws of the mobile blocks (10.10) and adjust the latter so that a secure linkage is assured.

If the manual release SMP... is used, place this between the valve spindle and the actuator shaft.

Then use the two spacing collars (10.13) supplied with the SMP..., instead of the threaded pins (10.5).

If too much space remains between the manual release and the actuator shaft, use one of the extensions (10.15) supplied with the SMP.

Using the manual control, make a couple of complete valve runs to check that the movement is uniform.

**9. OVERALL DIMENSIONS**

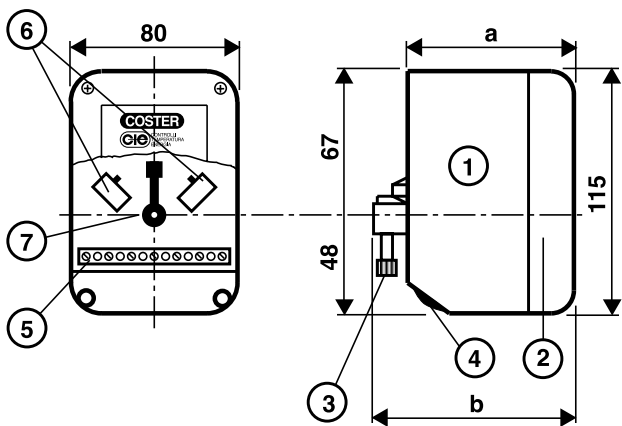

Model	a mm.	b mm.
CVC 18..- 09..- 03..	85	102
CVC 01..	110	127

- 1 - Base
- 2 - Protective cover
- 3 - Securing screws
- 4 - Plug for PG 11 cable entry
- 5 - Terminal block
- 6 - Miniature switches
- 7 - Cam

**10. INSTALLATION**

**Mounting without SMP 750 manual release**

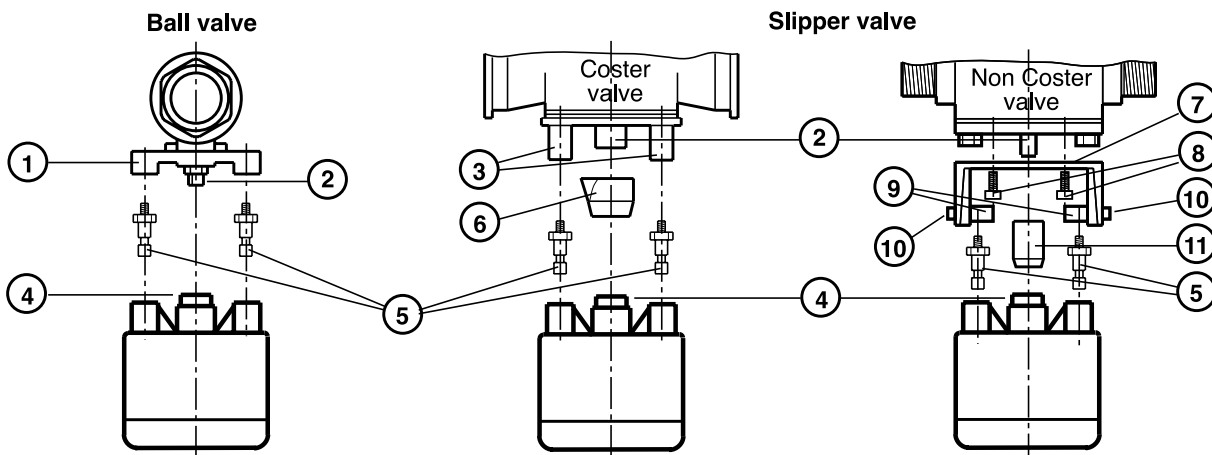

**Mounting with SMP 750 manual release**

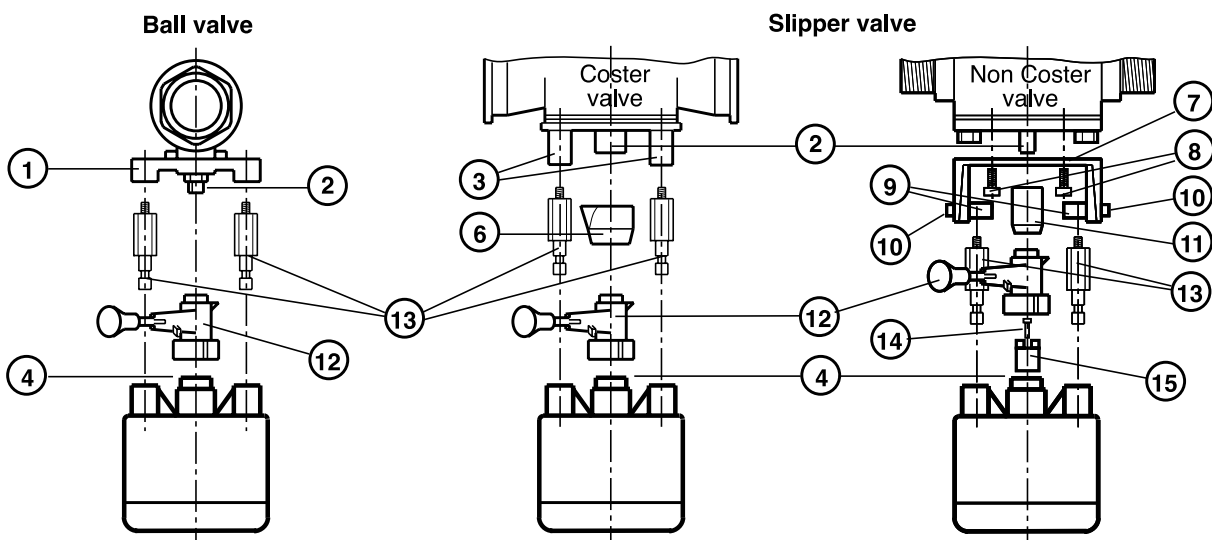

- 1 - Linkage support
- 2 - Valve spindle
- 3 - Screwed valve supports
- 4 - Actuator shaft
- 5 - Fixing pins

- 6 - Coster valve linkage
- 7 - Linkage bracket
- 8 - Linkage bracket fixing screws
- 9 - Screwed mobile blocks
- 10 - Fixing screws for blocks

- 11 - Non-Coster valve linkage
- 12 - Manual release
- 13 - Spacing collars
- 14 - Extension securing bolt
- 15 - Actuator spindle extension

5 e 6 : supplied with actuator  
 7...11 : supplied with AVA 101 and AVS 102  
 12...15 : supplied with SMP 750

**11. WIRING**

To make the electrical connections proceed as follows :

- remove the protective cover (loosen the four screws,
- introduce the electric cables into the actuator through the holes provided (9.4) to accept cable entry glands PG11,
- make the electrical connections, using 1,5 mm<sup>2</sup> cables, as shown in the diagram for the actuator model used, and in strict accordance with the relevant current safety regulations .
- replace the cover and tighten up the four screws.

**12. WIRING DIAGRAMS**

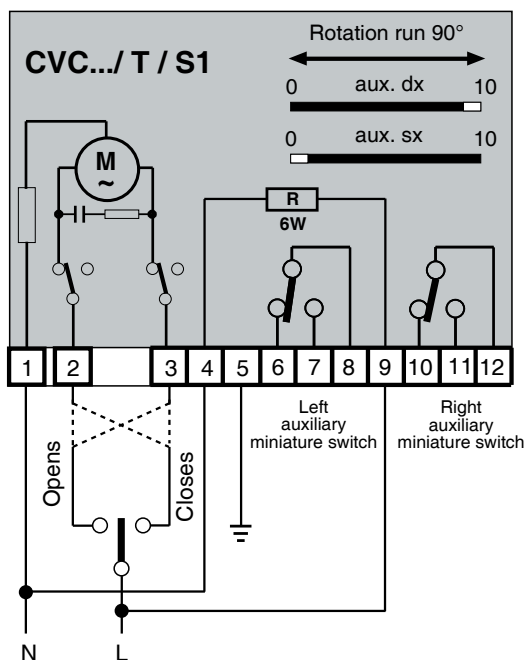
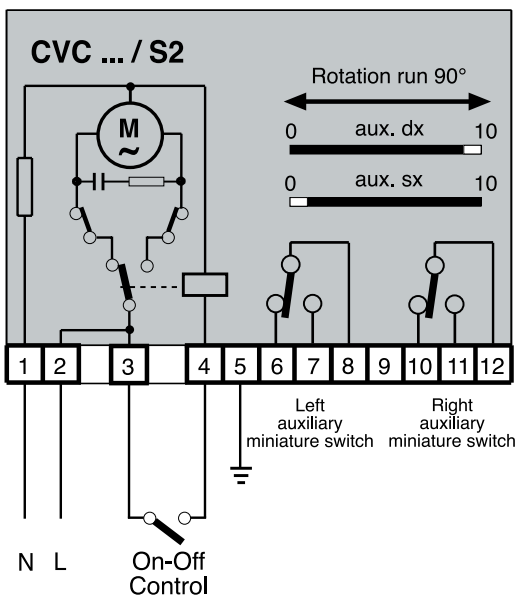
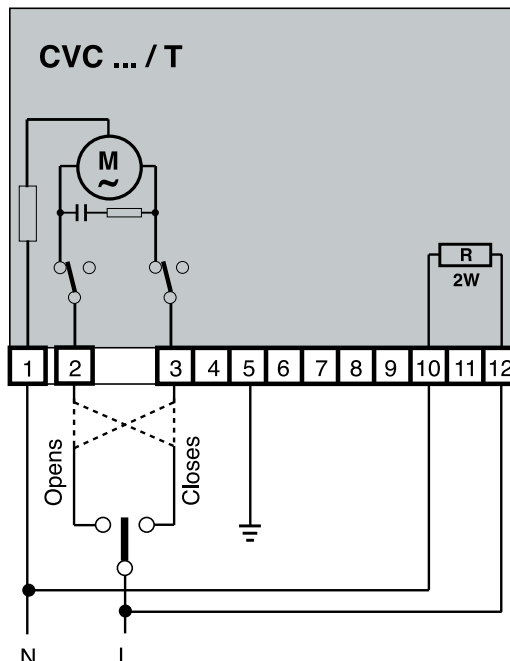
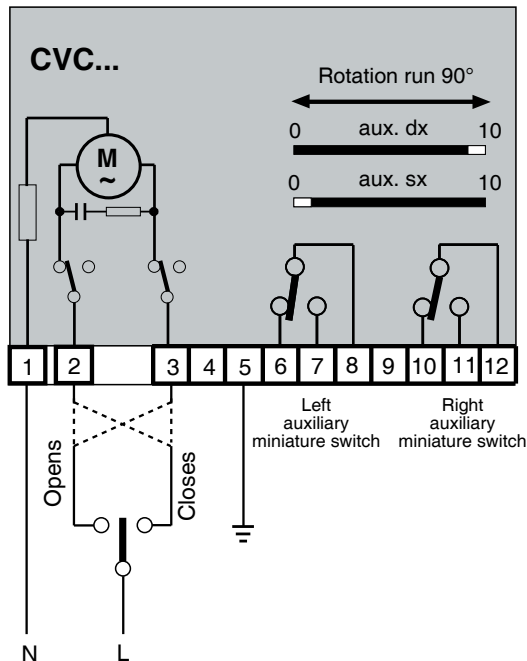

**Amendments to data sheet**

Date	Revision No.	Page	Section	Details of amendments
26.06.06 MZ		3	9. OVERALL DIMENSIONS	Amended diagram.
20.11.08 MZ	<b>01</b>	1 - 4	3. Special models - 12.Wiring diagrams	Insertion of new model CVC.../T/S1



Head Office & Sales  
 Via San G.B. De La Salle, 4/a Tel. +39 022722121  
 20132 - Milano Fax +39 022593645  
 Orders Fax +39 0227221239  
 Reg. Off. Central & Southern  
 Via S. Longanesi, 14 Tel. +39 065573330  
 00146 - Roma Fax +39 065566517  
 Shipping  
 Via Gen. Treboldi, 190/192 Tel. +39 0364773200  
 25048 - Edolo (BS) Tel. +39 0364773202  
 E-mail: info@coster.eu Web: www.coster.eu



D 33042

