

# REVERSIBLE ROTARY ACTUATORS FOR HGM - HMM - VDM VALVES

## CDK 06. - 03. Eng.



- EXTRACTABLE TERMINAL BLOCK
- RAPID MOUNTING ON VALVE
- POSITION INDICATORS
- 3-wire electric control (common, opens, closes)
- Auxiliary SPDT miniature switch
- Power supply: 230 V~ and 24 V~; IP 53 protection

### 1. APPLICATION

CDK 06. - 03. actuators are designed to operate COSTER HGM - HMM (ball) and VDM (ceramic disk) valves. The actuator is mounted directly on the valve so that no linkage kit is required.

### 2. OPERATION

CDK 06. -03. actuators incorporate a reversible synchronous electric motor with three-wire electric control (common, opens, closes). They can be controlled by an On-Off or modulating device (thermostat, switch, modulating controller) provided with an SPDT output switch.

The electric motor transmits the rotary movement to the mechanical reducing gear which governs the rotation speed of the output shaft and, accordingly, the actuator run time.

The actuator run is 90° and is limited by two miniature switches operated by an end-of-run cam.

They are fitted with two voltage-free SPDT auxiliary miniature switches (**switching takes place at approximately the half-run of the actuator**).

### 3. MODELS

Model	Power supply V~ (VA)	Run time seconds	Nominal torque kg/cm (Nm)	Starting torque kg/cm (Nm)	Valves (up to DN) HGM-HMM-VDM
<b>CDK 068</b>	230 (4)	60	15 (1,5)	30 (3)	1"
<b>CDK 064</b>	24 (4)	60	15 (1,5)	30 (3)	1"
<b>CDK 038</b>	230 (4)	30	10 (1)	20 (2)	3/4"
<b>CDK 034</b>	24 (4)	30	10 (1)	20 (2)	3/4"

### 4. OVERALL DIMENSIONS

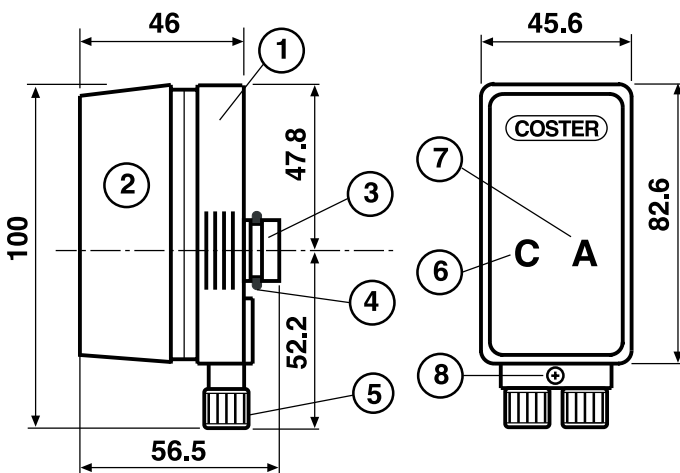

- 1 – Base
- 2 – Semi-transparent protective cover
- 3 – Coupling for valve
- 4 – Actuator/valve locking spring
- 5 – Unions for passage cables
- 6 – Indicator actuator closed (the “C” turns white)
- 7 – Indicator actuator open (the “A” turns white)
- 8 – Securing screws for terminal block protective cover

### 5. TECHNICAL DATA

Power supply :	CDK 068 - 038	230 V~ ± 10%
	CDK 064 - 034	24 V~ ± 10%
Frequency		50...60 Hz
Consumption:		4 VA
Protection		IP 53
Rotation angle		fixed at 90°
Run time		
CDK 06.		60 seconds
CDK 03.		30 seconds
Torque CDK 06. :		
Nominal		15 kg/cm (1.5 Nm)
Starting		30 kg/cm (3 Nm)
Torque CDK 03. :		
Nominal		15 kg/cm (1 Nm)
Starting		20 kg/cm (3 Nm)
Auxiliary miniature switch :		
maximum switching voltage		250 V~
maximum switching current		5 (1) A
Materials:		
Base		ABS with glass fibre
Cover		semitransparent polycarbonate
Valve fluid temperature		5...95 °C
Ambient temperature:		
Operating		0...45 °C
Storage		- 20...+ 60 °C
Weight		0.210 kg

**6. CONSTRUCTION**

The actuator base is made of ABS reinforced with glass fibre; the cover is in semitransparent polycarbonate. The closing position (4.6) and the opening position (4.7) are clearly indicated. Two openings, furnished with cable-strain relief bushing grips, permit the passage of the electric cables. The coupling device, at the rear of the base, permits rapid mounting of the actuator on the valve.

**7. ELECTRICAL CONNECTIONS**

- To ensure a good protection and seal, the outside diameter of the cables must be between 6.25 and 7 millimetres.
- To conform with regulation CEI 20-20 we suggest using the following cable types :
  - cable type H03VV-F with three wires x 0.75 mm<sup>2</sup> (2 + yellow/green),
  - cable type H03VV-F with four wires x 0.75 mm<sup>2</sup> (3 + yellow/green),
  - cable type FROR 300/500 V with three wires x 1 mm<sup>2</sup> (2 + yellow/green).
- Loosen the securing screw (4.8) and the two unions for the passage of the cables (4.5) and remove the protective cover from the terminal block.
- Slip the unions on to the cables.
- **To facilitate making the connections the terminal block can be removed.**
- Make the electrical connections following carefully the diagram in 10. WIRING DIAGRAM.
- Having made the connections, insert the terminal block (if it has been removed), replace the protective cover, tighten up the unions and then secure the whole with the securing screw..

**The union corresponding to the auxiliary switch connection terminals is closed so as to ensure the necessary protection for the actuator in the event that the auxiliary itself is not used. To connect it, it is necessary to open the union passage by breaking the internal protective membrane .**

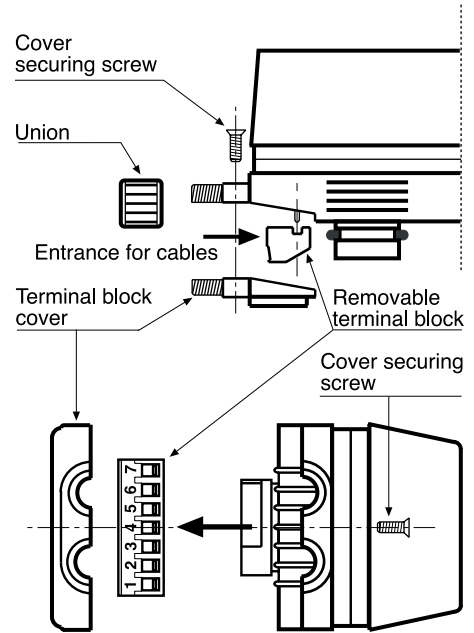

**8. MOUNTING THE ACTUATOR ON THE VALVE**

- Check the position of the milling on the actuator shaft.
- If necessary, rotate the valve spindle to make it coincide with the milling on the actuator shaft.
- Position the actuator on the valve by inserting the two pivot pins on the latter into the two corresponding holes in the base; then press hard on the head of the actuator until you feel it snap into position on the valve.
- Power the actuator and have it make a couple of complete runs to ensure it works correctly.

**9. INSTALLATION IN PLANT**

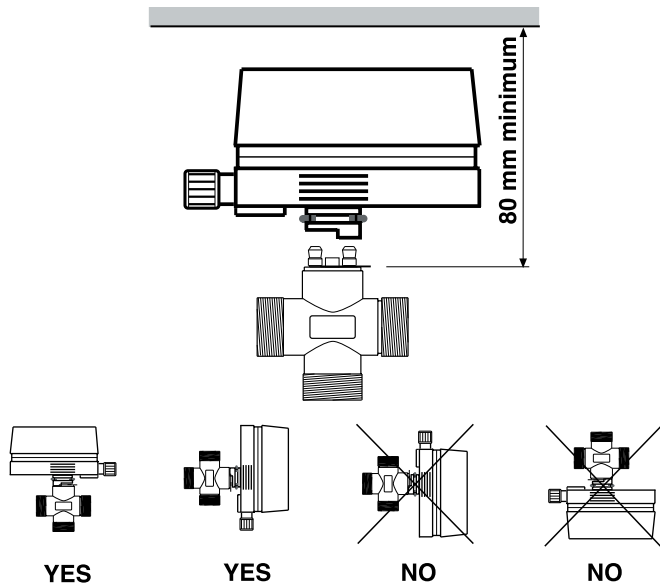

**10. WIRING DIAGRAM**

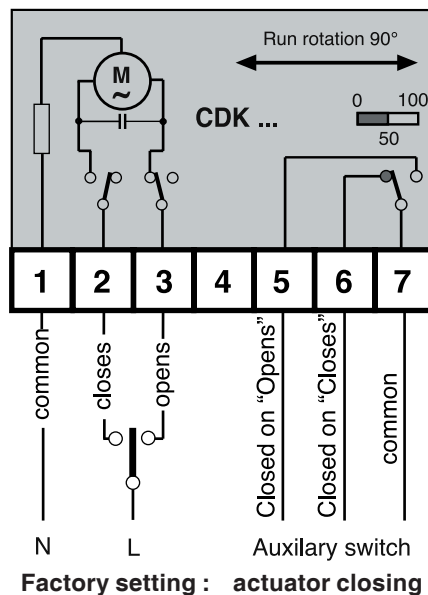

**Amendments to data sheet**

Date	Revision No.	Page	Section	Amendment description	Firmware version	Software version
08.10.08 AM	01	1	3. MODELS and 5. TECHNICAL ADATA	Add CDK 038 and CDK 034 models		



Head Office & Sales  
 Via San G.B. De La Salle, 4/a Tel. +39 022722121  
 20132 - Milano Fax +39 022593645  
 Orders Fax +39 0227221239  
 Reg. Off. Central & Southern  
 Via S. Longanesi, 14 Tel. +39 065573330  
 00146 - Roma Fax +39 065566517  
 Shipping  
 Via Gen. Treboldi, 190/192 Tel. +39 0364773200  
 25048 - Edolo (BS) Tel. +39 0364773202  
 E-mail: info@coster.eu Web: www.coster.eu



D33230