

THERMAL & REFRIGERATION ENERGY METER WITH ENERGY & VOLUME PULSE TRANSMITTER
Conforms to UNI EN 1434 standard
Conforms to Directive MID 2004/22/EC



IET 7183 C1 (230 V ~) Eng.
IET 7143 C1 (24 V ~) Eng.



- **Automatic energy metering :**
 - consumption of thermal (heating) and/or refrigeration (conditioning) energy;
- **Forwarding of energy and volume pulses:**
 - two optoisolated outputs for each energy & volume metering unit
- **Volumetric meter :**
 - mechanical or electronic meters (e.g. ultrasound, see section 10.2)
- **Communication system already incorporated:**
 - C-Bus for Telemangement via modem or local management via PC speed programmable from 1200 to 9600 baud
- **1 remote control output**
 - enabling remote control via Telemangement
- **Installation on pipework or on DIN rail**
- **Power supply : IET 7183 = 230 V ~ ; IET 7143 = 24 V ~**
 - battery incorporated for power in event of mains failure

QUICK REFERENCE :

- **INSTALLATION & WIRING DIAGRAM: SECTIONS 8, 9 & 10**
- **TESTING WIRING: SECTION 21**
- **ACCURACY RATING OF THE SYSTEM: SECTION 14**
- **SIMPLIFIED READ out OF THE UNIT: SECTION 16**
- **COMPLETE READOUT: SECTION 18**
- **SETTING FISCAL PARAMETERS: SECTION 20**

1. APPLICATION

The “universal” meter IET 7183 (or IET 7143), in conjunction with a volumetric meter, calculates the thermal and/or refrigeration energy used in heating and/or air conditioning zones.
 By means of C-Bus communication the meter can be connected locally or via Telemangement to a PC for readouts locally or at a remote site.
As of firmware version 13, transmission speed is programmable from 1200 to 9600 baud.

2. PRINCIPAL FUNCTIONS

- **METERING THERMAL & REFRIGERATION ENERGY:** the volumetric meter sends the pulses from measuring the volume of hot and/or cold water for metering as calories and/or frigories; while the flow and return sensors send the temperature values; the unit processes this data and calculates continuously the related energy, integrates it and records it.
- **FORWARDING ENERGY & VOLUME PULSES:** the unit is provided with two optoisolated outputs; each generates a pulse each time a certain quantity of energy is metered and of water flowing past.
 The measurement unit for volume and energy depend on the nominal flow of the volumetric meter.
- **POWER SUPPLY:** one of the two models is usually powered by 230 V~ and the other by 24 V~; a battery is incorporated which guarantees operation in the event of a temporary power failure. The battery will ensure operation for about three years of power failure.
- **DATA RECORDING:** all the basic data is recorded in two copies physically separated; a security system permits protecting this data from any critical events and restoring the original data.
- **DATA RECORDING (LOGGER):** all consumption data is recorded every week for 52 weeks; this represents a complete annual season of heating and air conditioning. Moreover, each week is recorded the peak (weekly) of the flow and of the power; these figures are processed at a programmable time interval
- **ALARM SYSTEM:** the unit processes 10 different types of alarm with a local or remote output; the alarms are recorded in the DATA LOGGER by type and time of event.
- **ADDITIONAL PROCESSING:** the unit continuously processes the flow of the fluid vector and the instantaneous power of the system. Moreover, it provides all the data of interest to a normal user and configuration data for the supervising engineer.
- **REMOTE CONTROL:** the unit is provided with a Remote Control output which can be enabled via Telemangement; its most common use is switching off the heating (e.g. closure of zone valve) for the user in arrears.

3. TEMPERATURE SENSORS

IET 7183 and IET 7143 are provided with two Pt 1000 temperature sensors calibrated in pairs, each with an electric cable of about 3 metres.
 Each of the two sensors is inserted in a pocket the length of which depends on the application.

4. GENERAL TECHNICAL DATA

4.1 Calculation units

Conforms ro Directive MID 2004/22/EC

Power supply :

IET 7143 24 V~; + 10% – 15%

IET 7183 230 V~; + 10% – 15%

Consumption 0.35 VA

Backup lithium battery 3.6 V - 2Ah

Autonomy without mains power 3 - 5 years

Enclosure DIN 6E module

Enclosure protection IP 54

Base + cover ABS

Display LCD

Volumetric meters for heating /air conditioning :

see sections 10.2 and 10.3 on page 5

Maximum measurable power 30,000 Kw

Maximum measurable flow 2,000 m³/h

Temperature range 0...170 °C

Temperature differential range 3...150 °C

Energy & volume outputs see section 10.5 and 10.6

Accuracy class = 2 see section 14 on page 7

Output alarm forwarding 24 V - 50 mA max

Ambient humidity Class F DIN 40040

Vibration test with 2g (DIN 40 046)

Accuracy class 2 (see section 14)

Ambience Class A

Ambient temperature :

- operation 5 to 55 °C

- storage - 25 to + 60 °C

Construction standard Italian Electr. Committee (CEI)

Dimensions 106 x 119 x 56 mm

Weight 0.4 kg

4.2 Sensors

Conforms ro Directive MID 2004/22/EC

Precision see section 14 page 7

Type Pt 1000

Measurement temperature range 0...150 °C

Difference temperature return/flow range 3...150 °C

Cable section 2 x 0.5 mm²

Standard cable length 3 m

Special length cable 10 m

Essential accessories:

Pair of pockets for sensors (brass or stainless steel) GIS ...

- thread 1/2"

- depth 2 measurements: 25 and 45 mm

Standards :

Specific standard for the meter UNI EN 1434

Immunity from electric disturbances & RF CEI EN 61000

• Telemangement

Speed C-Bus chosen from 1200, 2400, 4800, 9600 bauds

5. OVERALL DIMENSIONS & FACIA

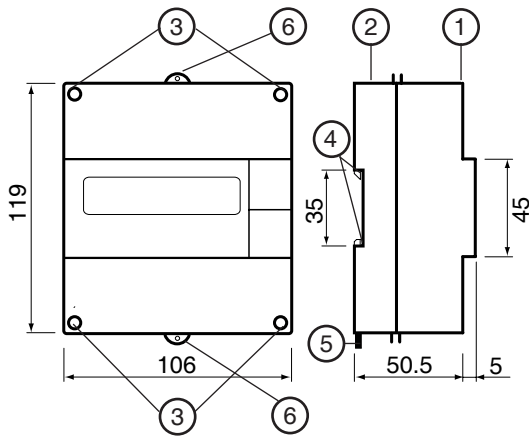

- 1 – Body and protective cover
- 2 – Base with transformer, components & terminal blocks
- 3 – Screws for securing base and cover
- 4 – DIN rail securing elements
- 5 – DIN rail release lever
- 6 – Perforated “Ears” for seals

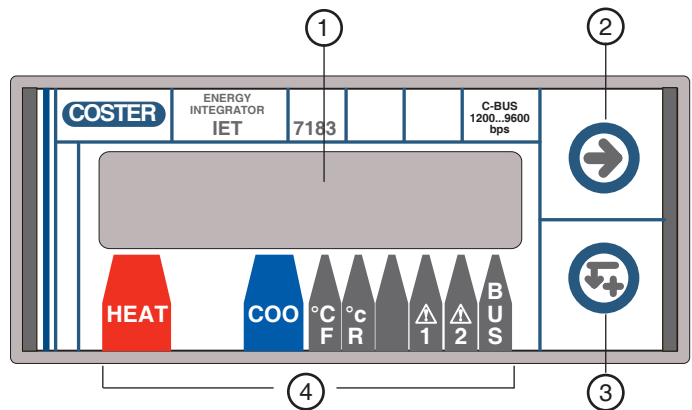

- 1 – Display: on display are included arrows for indicating the data shown at a particular moment.
- 2 – Key for advancing pages.
- 3 – Key for diverting from menu and increasing adjustable parameters,
- 4 – Indicators of the pages displayed at that moment

6. INSTALLATION OF METER ON PIPE OR WALL

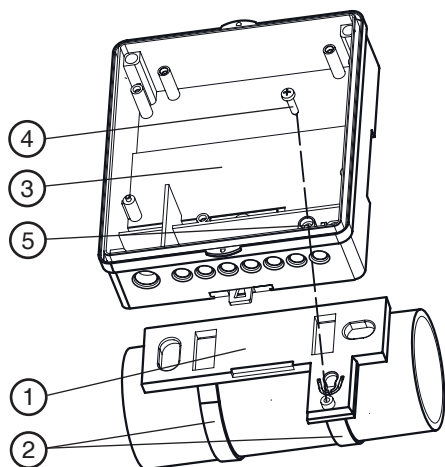

- 1 – Universal fixing plate
- 2 – Bands to pass through the openings in the plate and secure around the pipe
- 3 – Meter base, shown without the printed circuit, to fix on the plate.
- 4 – Screw for securing base to fixing plate; this screw is housed near to the hole (5)

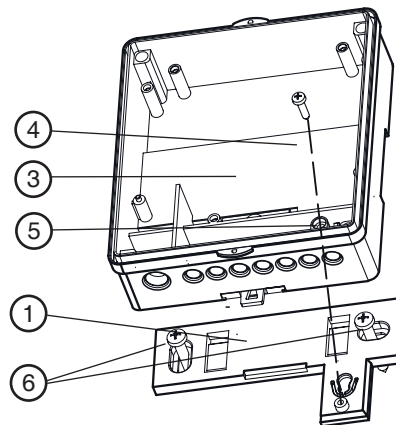

- 5 – Hole for passing through the screw (to be pierced by a screwdriver). The hole is closed by a thin layer of plastic to ensure IP 54 protection. Tighten up the screw.
- 6 – Screws for securing the plate to the wall

7. TEMPERATURE SENSORS & RELATED POCKETS

7.1 Important instructions for the correct installation of the sensors

- The sensors are inserted in the pockets and pressed as far as they will go, in order to be sure that they detect the fluid temperature; if the sensors are only partially inserted in the pockets they may measure the temperature incorrectly. The sensitive part of the sensor is the extremity of the small metal cylinder.
- The sensor can be sealed in order to prevent tampering; tighten by hand the screw of the seal and pass the seal wire through the hole and the groove of the hexagon.

7.2 Pockets (not included with the meters)

The pockets are available in various models, sizes and materials, according to type of application.

STANDARD BRASS POCKETS (supplied in pairs)

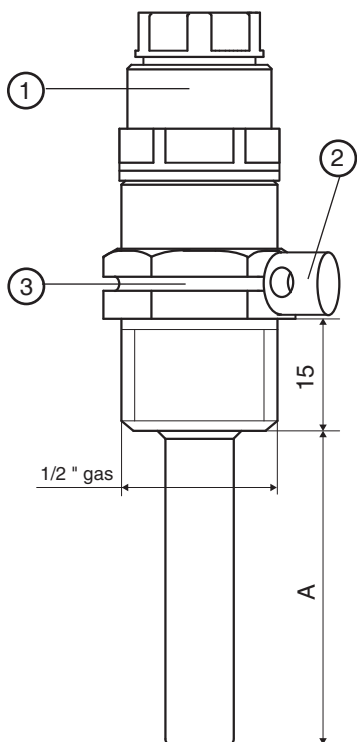

A	BRASS
25	GIS 025
45	GIS 045

These pockets are in packages of two.

Other pockets are available with different depths, for any pipe diameter. See the sensors & pockets section of the catalogue.

- 1 - Grommet for passage of sensor cable
- 2 - Knurled and perforated screw for securing sensor cable (tighten only by hand)
- 3 - The seal cable should be threaded through the hole in the knurled screw and pulled along the groove; it should then be sealed.

POCKETS ON BRASS "T" SLEEVE (supplied in pairs)

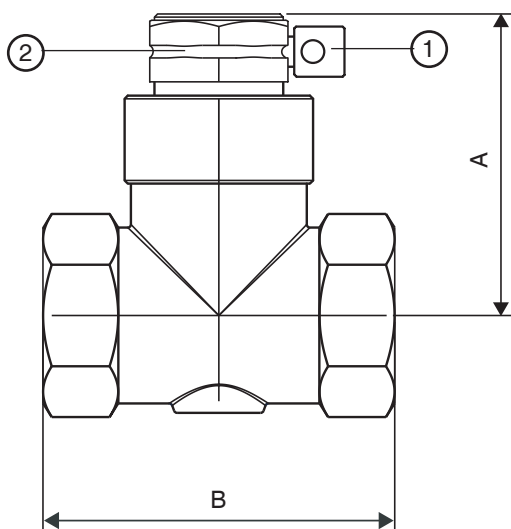

Misc.	A	B	Model
1/2"	45	56	ART 015
3/4"	45	56	ART 020
1"	42	62	ART 025

Each item represents a pair of pockets & T sleeves for the flow & return sensors

- 1 - Knurled and perforated screw for securing sensor cable (tighten only by hand).
- 2 - The seal cable should be threaded through the hole in the knurled screw and pulled along the groove; it should then be sealed.

8. SITING & INSTALLATION

The unit must be installed in a dry location that respects the permitted ambient conditions given under 4. TECHNICAL DATA. It must be connected to an electrical installation constructed according to standard IEC 79-14 (CEI EN 60079-14) and sited in a non-dangerous area meeting standard IEC 79-10 (CEI EN 60079-14); that is, an area in which there is no potentially explosive quantity of gas requiring special measures for the construction, installation and use of electrical plant.

It can be mounted on a DIN rail and housed in a standard DIN enclosure or connected directly to a pipe using the accessories supplied: the pipe must be insulated or must not reach temperatures above 40°C, nor below ambient temperature (cooling), to prevent condensation.

9. ELECTRICAL CONNECTIONS

Proceed as follows :

- Separate the base from the unit
- Mount the base on the DIN rail or other suitable place and check that the securing elements (5.4) anchor it securely
- Make the electrical connections according to the diagram and in respect of the safety standards in force using the following cables: :
 - 0.75 mm² for power supply; the total diameter of the cable must be less than 7 mm. in order for it to pass through the rubber grommet and ensure a good seal
 - 0.35 mm² for the sensors or for any other input or output; the total diameter of the cable must be less than 5 mm.
- The sensors are already supplied with a cable of this type 3 metres long; for greater lengths see section 10.1.
- If the power supply is 24 V~ (IET 7143) **WARNING: the 24V~ supply can present problems if 230/24 volt transformers of poor quality are used. The transformer has to ensure that the voltage does not rise above 24 volts + 10% even when used without a load: the consumption by the electronic unit is so small that it does not create any operational problem for the transformer.**
- Programming of jumpers P1, P2, P3, P4 and Z6 on the terminal board.

These must be configured at the time of installation and wiring of the device.

There are five jumpers: P1, P2, P3 and Z6.

 - **JUMPER P1** : serves to connect the battery to the circuit; during storage the battery is disconnected by means of this jumper in order to avoid discharging it should it not be used for a long tim.
 - **JUMPER P2** : serves for programming output G (power supply ultrasound sensors or similar) between 3.6 and 5 volts. See wiring diagram section 10, output G.
 - **JUMPER P3** : serves for programming the pulse output of the volume that can be either equal to the pulse output of the volumetric meter or with the metering unit already processed by IET 71..
 - **JUMPER P4**: serves to program the type of volumetric meter for heating/cooling.
 - **JUMPER Z6**: permits changing to "high resolution" mode. The total meter readings (MWh alternating with TOT and m³ alternating with TOT), not adjusted, are displayed using a multiplication factor of 1000.

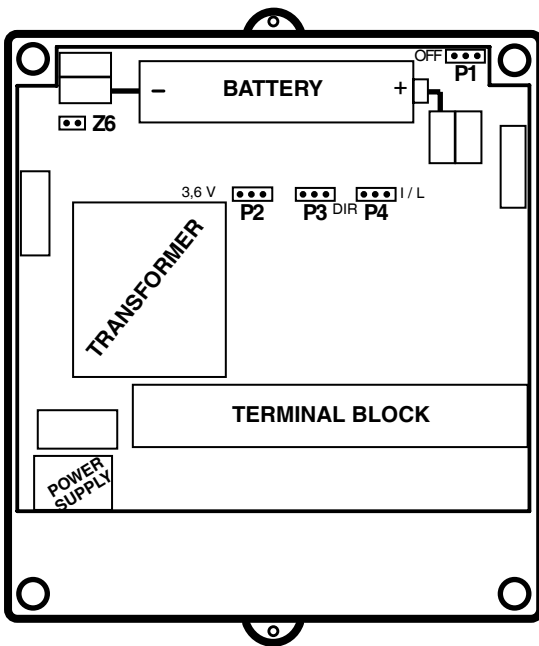

- **JUMPER P1**
 - = Battery disconnected (factory setting)
 - = Battery connected (operating condition)
- **JUMPER P2**
 - = Output G at 3.6 Volt (factory setting)
 - = Output G at 5 Volt
- **JUMPER P3**
 - = Output volume pulses processed as standard measurement units by IET 71... (**INDIRECT mode**)
 - = Output volume pulses equal to those emitted by volumetric meter (**factory setting: DIRECT mode**)
- **JUMPER P4** (from C2 version)
 - = litres/pulse (factory setting)
 - = pulses/litre
- **JUMPER Z6** (from C2 version)
 - = Normal operating mode (factory setting)
 - = High resolution mode

N.B. only for tests during first field test

- Switch on the power and check its presence at terminals L and N.
- Switch off power, replace cover on the base/terminal block and switch on power again.
- After these operations the meter will be in operation, even without external power, since it is battery-powered.

WARNING: The display, even when the unit is powered, may not light up immediately. If this should happen, press key or wait for a maximum of one minute when the display will automatically light up.

The next operations are :

- **Setting the time and date on the clock** (section 18.3 – M8.2 and subsequent displays on page15): it is useful, at this stage, to start the clock, since after the body and protective cover has been detached from the base for about 24 hours the clock battery becomes exhausted. When the body and protective cover is inserted on the base the clock is powered by the battery which keeps it functioning for years even without mains power.
- **If required, setting fiscal parameters and alarms**: if the unit has not been calibrated before installation this must be done as described in section 18 on page 14.
- Having concluded all the checks, secure the cover with the four screws provided (figure 5.3) and apply the seals to the "ears" (figure 5.6)

10. WIRING DIAGRAM

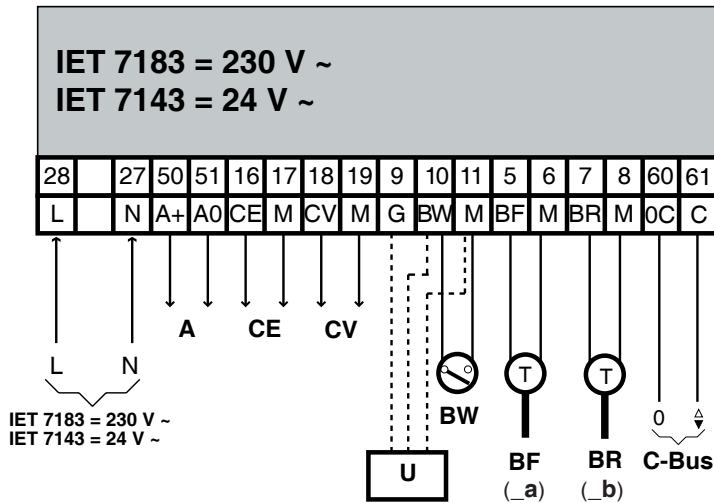

The numbers above the symbols are those required by international standards

- L - N = Live and neutral of power supply: 230 or 24 V 50Hz according to model.
- A = Output which closes in presence of any type of alarm
This same output can also be used for remote control (from update C1)
The output is of the Open Collector (optoisolated) type
- A+ = positive of Open Collector
- A0 = negative of Open Collector
- CE = Output for energy pulses.
This output is of Open Collector (optoisolated) type
- E+ = positive of Open Collector
- E0 = negative of Open Collector
- CV = Output for volume pulses.
This output is of Open Collector (optoisolated) type
- V+ = positive of Open Collector
- V0 = negative of Open Collector
- BW = Pulse transmitter volumetric meter (mechanical, magnetic or similar) fluid vector heating/cooling
- U = as alternative to BW = connection with ultrasound volumetric meter with "BURST" type output or frequency modulation
- G = power for ultrasound sensors or similar: choice of 3.6 V or 5 V (see jumper P2, section 9)
- BW = Input pulses ("BURST" or frequency modulation)
- M = 0 V
- BF = Flow temperature sensor, labelled _a (Pt 1000)
- BR = Return temperature sensor, labelled _b (Pt 1000)
- C-Bus = Local or remote communication bus (speed from 1200 to 9600 bps)

WARNING: The 24 V power supply can present problems if 230/24 V transformers of low-quality are used. The transformer must guarantee that the voltage does not rise above 24 V + 10% even when used without load: the consumption by the electronic unit is so low that it hardly loads the transformer.

FOR WIRING THE SENSORS AND VOLUMETRIC METERS READ CAREFULLY THE NEXT THREE SECTIONS

10.1 Connection of the temperature sensors

The sensors are supplied with 3-metre cables (SPT 031 sensor).
The sensor cables, for certification reasons, **MUST NOT BE SHORTENED NOR LENGTHENED.** You are strongly recommended to install the calculation unit, securing it to the wall or on the pipework, so as to avoid joints for extensions in the sensor cables.
Should cable length be insufficient for installation reasons, order SPT 010 sensors, supplied with 10-metre cables.

10.2 Volumetric meters with pulse transmitter "litres per pulse" (mechanical, magnetic or similar)

This type of meter has an output of pulses, each of which represents a certain number of litres: litres per pulse; for example, mechanical meters (pulse transmitted by means of voltage-free switch) and magnetic meters (transmit pulses to an open collector or similar).

Minimum time switch of pulse transmitter closed: 200 mseconds.

Minimum time switch of pulse transmitter open: 800 mseconds.

Maximum speed of metering: 1 pulse per second.

Normally the meter has a two-wire cable three metres long.

For the electrical connections follow these instructions:

- up to 3 metres it can be connected directly to the terminal block.
- **over 3 meters, extend it with screened cable (2 wires + screen) up to a maximum of 30 meters, connecting the screen only to point M of the terminal block.**
- in the event of doubt or where there are existing installations which fall outside this advice, consult COSTER technical staff to find solutions that do not require the re-design of the wiring.

If possible, avoid laying the meter cabling alongside power cables (230 V); use different channels.

10.3 Volumetric meter with pulse transmitter "pulses per litre" (BURST for volumetric ultrasound)

This type of meter has a pulse output; for each litre flowing past a certain number of pulses is emitted: **pulses per litre**; for example volumetric ultrasound meters.

- **meter with output of "pulses per litre" type (COSTER ultrasound KSG.../KSF...).**

WARNING: Configure;

- **JUMPER P4** in "pulses per litre" position
- **SWITCH No. 7** in "pulses per litre" position

This meter already has an output which can be correctly coupled with the input and so the 3-metre cable can be extended to 30 metres without causing problems; for greater lengths consult COSTER technical staff. However, it is always advisable not to run the cable near to power cables (230 V).

- **ultrasound meters of other manufacturers:** generally IET 71.. is compatible with all the volumetric meters in common use. To be sure about compatibility consult COSTER technical staff.

The electrical features of the IET 71.. input are:

Minimum time of pulse : 1 msecond.

Minimum time between 2 pulses: 18 mseconds with high impedance meter output (e.g. Open Collector)
5 mseconds with low impedance meter output

If the volumetric meter has these features it is perfectly compatible.

10.4 Output alarm and/or Remote Control (A)

Output A is optoisolated with Open Collector: maximum 24V- and maximum 50 mA.

This output is compatible with all the alarm inputs of COSTER electronic devices.

10.5 Local or remote (Telemanagement) readout of the unit from PC

The unit is provided with a standard C-Bus output for local or remote readout of all the data and for certain non-fiscal settings.

For remote readout C-Bus is used according to the standards already described in the general data sheet on C-Bus.

For local readout it is necessary to use a PC connected to C-Bus via ACB 232 convertor cable or connected to the appropriate connector of other C-Bus amplifiers (e.g. PCB 432), using a normal cable for RS232.

10.6 Transmitting energy pulses

The CE output transmits a pulse every 1 KW hour or 10 KW hour or 100 KW hour, according to the output weight of the volumetric meter and to the type of output (litres/pulse or pulses/litre).

The transmitted pulses have a duration of 100 ms; if more than one pulse is to be transmitted the time interval between one pulse and the next is 2 seconds.

Meter output litres per pulse (l/p)	Meter output pulses per litre (p/l)	Energy per pulse transmitted
Up to 10 litres/pulse	25 pulses/litre & over	1 KW hour
over 10 & up to 100	below 25 up to 5	10 KW hour
over 100	below 5	100 KW hour

Example 1: Woltmann meter of 60 m³/h, with pulse transmitter 1000 litres/pulse = 100 KW hours each pulse transmitted by IET 71...
 Example 2: ultrasound transmitter of 6 m³/h, with pulse transmitter 10 pulses/litre = 10 KW hours each pulse transmitted by IET 71...

Note : the pulses recorded are forwarded after a maximum time of 15 minutes

10.7 Transmission of volume pulses processed by IET 71.. (INDIRECT mode)

The CV output transmits a pulse every 1 or 10 or 100 or 1000 litres, according to the weight of the output of the volumetric meter and to the type of output (litres/pulse of pulses/litres).

The pulses transmitted have a duration of 100 ms; if more than one pulse is to be transmitted the time interval between one pulse and the next is 2 seconds.

Meter output litres per pulse (l/p)	Meter output pulse per litre (p/l)	Energy per pulse transmitted
Up to 1 litres/pulse	100 pulses/litre & over	1 litre
over 1 & up to 10	below 100 & up to 10	10 litres
over 10 & up to 100	below 10 & up to 5	100 litres
over 100	below 5	1000 litres

Example 1: Woltmann meter of 60m³/h, with pulse transmitter of 1000 litres/pulse. Each pulse transmitted by IET 71.. = 1000 litres.
 Example 2: ultrasound transmitter of 6 m³/h, with pulse transmitter of 10 pulses/litre. Each pulse transmitted by IET 71..= 10 litres

This transmission of pulses is of the indirect type since it is not a copy of what the volumetric meters transmit, but is already the processed volume which, by means of an external meter, can be measured in a second way for safety.

Note: the pulses recorded are transmitted after a maximum interval of 15 minutes.

Application example: connection of the signal to an external processing system for its viewing and/or control (supervision system, PLC etc.)

10.8 Transmitting volume pulses in DIRECT mode

The CV output transmits exactly the same pulses received from the volumetric meter, the same number and form and without any processing by IET 71.., if not with the addition of special insulation so as to have longer connecting wires without problems. This output is used for calculating the instantaneous flow very quickly and accurately, without the delays inevitably introduced by the IET.. microprocessor.

Example of application: automatic limitation of the primary flow in District Heating sub-stations.

If COSTER XTT 618 or XTT 608 controllers are used, please refer to the application examples provided in technical factsheets B 283, page 3 (XTT 618) and B 284, page 4 (XTT 608).

11. IMMUNITY FROM ELECTRICAL DISTURBANCES & RADIO SIGNALS

Since the meter incorporates an historic memory of consumption from the moment of its installation, it is designed to provide the maximum security for the data stored in this memory, even in the presence of electrical and radio disturbances.

On the basis of the above tests the meter has been assigned to **Class A** – the highest recognized by the standards.

Class A does not specify particular measures when laying the cables necessary for the installation of the unit; however, particular care is recommended to ensure a high degree of safety.

Data protection: in section 16.8 on page 10 is described the procedure for protecting the data.

Even if the unit should suffer irreversible damage, malicious or not, the data recorded always remains in memory; this data can be recovered by COSTER using a special procedure in its own workshops.

12. LABELING OF METERS

The meters are labelled according to the requirements of MID 2004/22/EC.

Since the unit is universal, it can be connected to a volumetric meter of any type and size and calibrated accordingly.

These data appear on the display, once the coupling with the volumetric meter has been made.

The data on the display are reliable, since the coupling is memorised in the unit and is protected by a seal.

13. ACCURACY OF THE CALCULATION UNIT

The maximum error of the calculation unit is less than that required by EN 1434 (2007) Directive.
This maximum error is shown in the following formula:

$$E_c\% = \pm \left(0.5 + \frac{\Delta T_{\min}}{\Delta T} \right) \quad \text{where : } \Delta T_{\min} = \text{difference flow/return minimum (3}^\circ\text{C)}$$

$\Delta T = \text{actual difference between flow and return}$

Examples : with actual ΔT reale di 3 °C the maximum error accepted by the regulations becomes $\pm 1.5\%$
with actual ΔT of 10°C the maximum error accepted by the regulations becomes $\pm 0.8\%$
with greater actual ΔT s the error is reduced.

14. ACCURACY OF THE PAIR OF TEMPERATURE SENSORS & OF THE SYSTEM

The maximum error of the pair of sensors is lower than that prescribed by the EN 1434 (2007) Directive.
The maximum error on the difference between the flow and return temperatures is given by the following formula:

$$E_t\% = \pm \left(0.5 + 3 \frac{\Delta T_{\min}}{\Delta T} \right) \quad \text{where : } \Delta T_{\min} = \text{difference flow/return minimum (3 }^\circ\text{C)}$$

$\Delta T = \text{actual difference between flow and return}$

Examples : with actual ΔT of 3°C the maximum error accepted by the regulations becomes $\pm 3.5\%$
with actual ΔT of 10°C the maximum error accepted by the regulations becomes $\pm 1.4\%$
with greater actual ΔT the error is reduced.

THE TOTAL ERROR PERMITTED BY THE REGULATIONS FOR THE CALCULATION UNIT INCLUDING SENSORS, IS THE SUM OF THE TWO PARTIAL ERRORS.

Examples : with actual ΔT of 3°C the maximum error accepted by the regulations becomes $\pm 5\%$
with actual ΔT the maximum error accepted by the regulations becomes $\pm 2.2\%$
with greater actual ΔT the error is reduced.

15. STRUCTURE OF PAGES ON THE DISPLAY (EXCLUDING FISCAL SETTING)

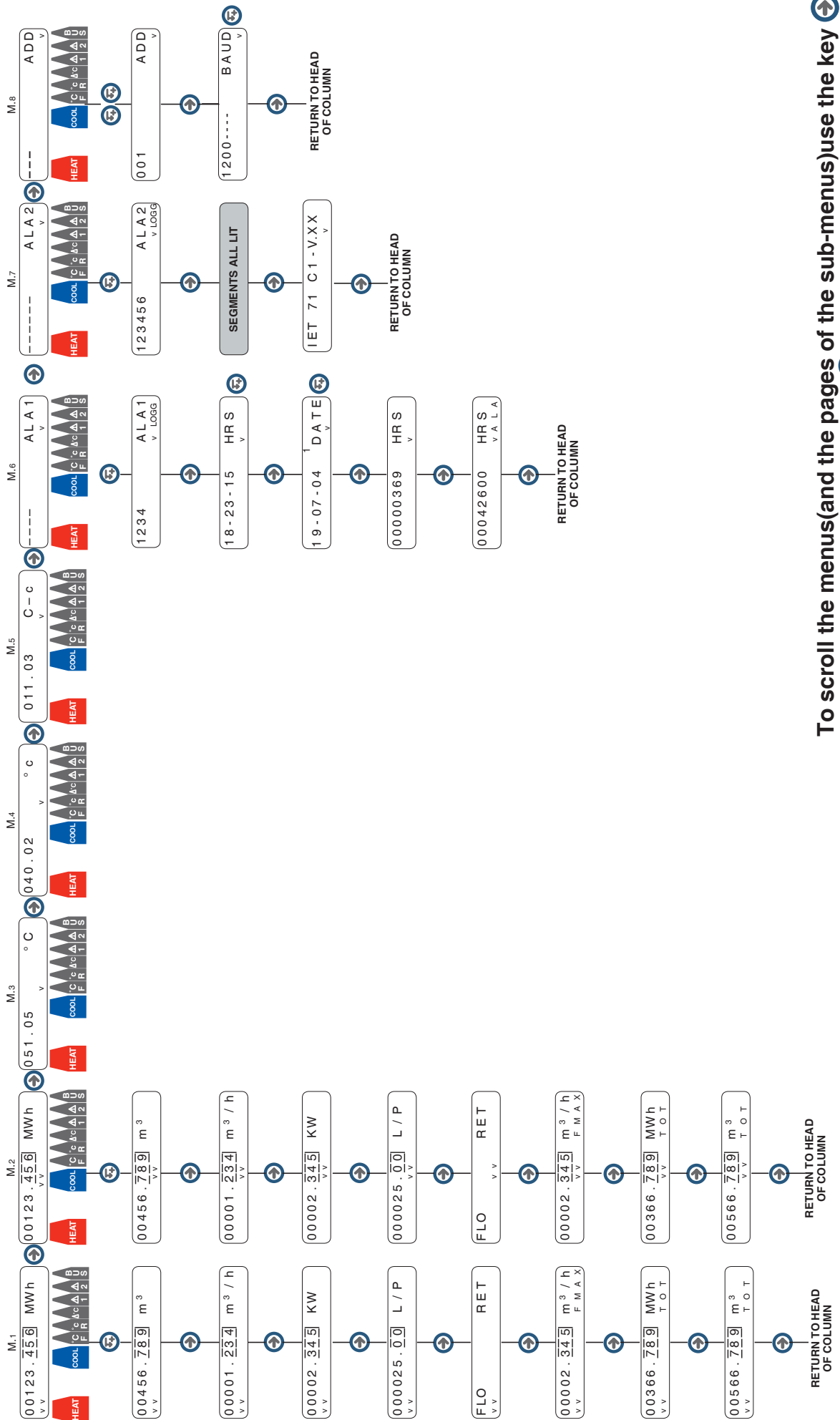

To scroll the menus (and the pages of the sub-menus) use the key

To enter sub-menus use the key

16. MINIMUM INDISPENSABLE SETTING OPERATIONS; SIMPLIFIED READOUT OF UNIT

In this section are described the minimum indispensable settings and other operations essential for correct operation of the unit and the simplified readout..

16.1 Minimum indispensable settings & other operations

The settings & other operations described below are the minimum required for putting IET 71.. in working condition.

- **Connecting the battery:** move jumper P1 to the right (see section 9. ELECTRICAL CONNECTIONS).
- **Correct setting of the value for litres per pulse or pulses per litre** of the volumetric meter used (heating/cooling); see pages M.1.1 TF, in sections 20.5 and 18.6.
If the above data are not correctly entered the meter will function erroneously.
- **Setting time of day:** page M.8.2 of section 17.3.
- **Setting of C-Bus communication speed** (from 1200 to 9600 baud), see page M.8.2, section 18.3
- **Setting C-Bus address**, if local or remote management used: page M.10.1 of section 17.3.
- **Complete readout of the meter** to check the above actions.

16.2 Simplified readout of the unit

In this section is described the simplified readout of all the metering parameters for normal use.

The decimals in the readouts are after the point: to indicate them more clearly, the standards require that the decimal figures are clearly distinct from the whole numbers; for this reason the decimal figures are highlighted by dashes.

The "v" indices are placed automatically above the diagrams which indicate by means of symbols the significance

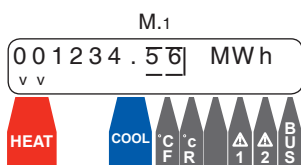

First page which always appears on the meter when the power is switched on; when the power is switched off, the page appears by pressing

The metering in MWh (aligned if necessary) summed by conditioning (frigories), if programmed, otherwise this page is skipped.

Press

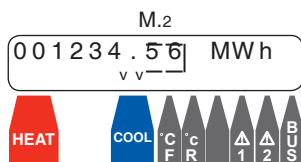

This is the metering in MWh (aligned if necessary) summed by conditioning (frigories), if programmed, otherwise this page is skipped.

Press

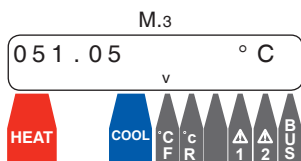

This is the plant flow temperature

Press

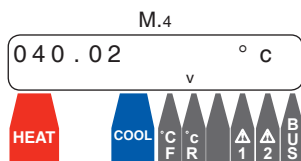

The plant return temperature

Press

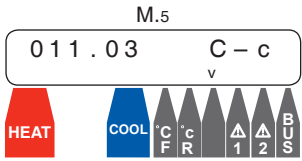

The difference in temperature between flow and return; this difference will be positive with heating and negative when there is conditioning.

Press

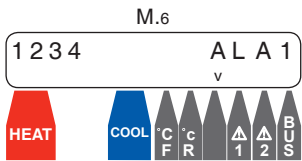

There are four alarms in the first group (ALA 1), arising from external signals of faults: if there are none, in place of the number will appear –.

Alarm 1 = flow sensor fault or disconnected for at least one minute

Alarm 2 = return sensor fault or disconnected for at least one minute

Alarm 3 = the electronic part of the base detached

Alarm 4 = alarm for absence of flow: this alarm is triggered when the temperature difference is above a certain threshold (can be set via Telemangement) and no pulse arrives from the volumetric meter for a certain period of time (can be set via Telemangement).

Press

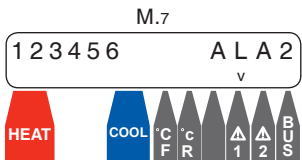

The six alarms of the second group (ALA 2), arising from internal operational faults: if there are none, in place of the number will appear –.

Alarm 1 = corruption of both the memories (irreversible error); the meter must be serviced by COSTER.

Alarm 2 = corruption of one of the two memories: this error is automatically corrected and disappears when the memory functions correctly again.

None of the basic meter readings suffer damage.

Alarm 3 = exceeding the threshold of maximum flow by the heating and/or cooling vector fluid for a certain period of time programmable via Telemangement.

Alarm 4 = exceeding the number operational hours (programmable via Telemangement) after which the standards require the recalibration of the system (usually seven years).

Alarm 5 = alarm clock: this alarm triggers when the clock incorporated in the unit shows incongruent times and dates.

Alarm 6 = alarm for use of incorrect base for the electronic unit: this alarm is triggered when, in error, the electronic unit is inserted on a base which is not compatible because it is of a different model.

Press

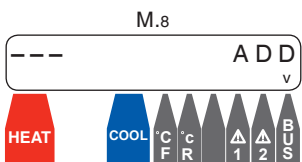

On this page is shown the Telemangement address: how to change it will be ADD explained later

--- = at the factory the address is set at the value --- : meter not running.

To connect a local PC or for Telemangement, enter desired address

Press

Returns to the first page (M.1) and the cycle can be repeated

NOTES :

- The alarms GROUP ALA1 and ALA2 appear at the moment at which they are triggered, and disappear when they cease; the date and time of up to 10 events are recorded..
- The readout of the temperature is updated within a few seconds.
- All the meter readings are updated within a few seconds.

17. FUNCTIONS OF THE SYSTEM

17.1 Measurement of flow and return temperatures

The measurement of the flow and return temperatures, by means of type Pt1000 sensors, takes place by means of a system which automatically calibrates the data monitored by the sensors in order to be completely independent of any conditions which may change over time.

Since the energy calculation depends on the difference between the two temperatures, the differential accuracy of the temperature measurements is heightened, bringing it to $\pm 0.05^{\circ}\text{C}$ (5 hundredths of a degree); the two sensors are coupled to each other in order to ensure this accuracy.

17.2 Measurement of the flow of heating and/or cooling vector fluid

The method varies according to the type of pulses coming from the volumetric meter:

- **Pulse type “litres per pulse”:** the volumetric meter transmits a pulse when it has totalled a certain number of litres flowing past it; this number can be entered in the integrator at the calibration stage.

This type of volumetric meter includes: the mechanical turbine meters, the magnetic and similar meters.

In this category are included certain ultrasound meters.

- **Pulse type “pulses per litre”:** the volumetric meter (usually ultrasound) transmits about every 1-2 seconds a certain number of pulses for each litre flowing past in those seconds. This method is complementary to the previous one and has the same accuracy; but has the advantage of providing information every 1-2 seconds and this permits reconstructing more rapidly both the volume and the flow for further processing.

By means of these pulses, the integrator meters the volumes of fluid flowing past for further calculations.

The integrator can be calibrated for any type of volumetric meter, from the smallest to the largest.

17.3 Calculation of energy

The energy (measured in KW h) is calculated as a product of the difference in temperature between flow and return and the quantity of vector fluid; this product is multiplied by a coefficient which takes into account the thermal capacity of the water and of the specific gravity, which varies according to the temperature.

$$\text{KWh} = \text{m}^3 \times (\text{Tf} - \text{Tr}) \times \text{K}$$

KWh = energy integrated (metered)

m^3 = cubic meters of vector fluid flowing through the meter

(Tf - Tr) = difference between flow temperature (T_a) and return temperature (T_b) (of the system or other user)

K = coefficient of thermal capacity and specific weight of the water; for the precise definition of this coefficient, the formula and tables drawn up by D. Stuck & Co. and contained in UNI EN 1434 standard, have been used.

On the display the figures are shown as MWh (1 MWh = 1000KWh) for ease of reference

17.4 Separation of thermal and refrigeration energy

IET 7183/7143 meters can separate thermal energy (heating) from refrigeration energy (cooling); the distinction is made by noting the minus sign (Tf - Tr); if the difference is positive, thermal energy is being metered (flow warmer than return); if the difference is negative, refrigeration energy is being metered (flow cooler than return).

The meter can be configured for metering thermal energy only (site for heating only) or for metering thermal and refrigeration energy (site for winter heating and summer cooling).

- **Meter for thermal energy only:** all the energy, when the temperature difference is more than 0.1°C , is stored in the thermal energy meter. All the m^3 flowing past are always stored in the respective meter.

It may happen, particularly in summer or when the boiler is switched off but with the pump in operation, that the difference in temperature becomes negative, even if only slightly; in theory, this corresponds to refrigeration energy; this energy is not calculated but the flow is always calculated, so that any external flow meter (m^3) carries out the same metering as the electronic meter.

- **Meter for thermal & refrigeration energy:** all the energy, with temperature difference greater than 0.1°C , is stored in the thermal energy meter; while all the energy with a difference of temperature below -0.1°C (difference obviously negative) is stored in the refrigeration energy meter.

The fluid vector is also divided into the thermal part and the refrigeration part: clearly, the sum of these two values gives the total of m^3 flowing past, a total that must be equal to the figure indicated on any mechanical meter.

WARNING: Via local PC or Telemangement it is possible to disable the metering of refrigeration energy when the flow temperature (e.g. conditioning) exceeds a value on the scale (from 20 to 30°C).

This function is described in section 22.2 on page 22.

17.5 General alarm functions

All the alarms ALA 1 and ALA 2 are described in section 16.

The meters IET 7183/7143 are able to operate even during alarm status, except:

- ALARMS 1 & 2 of GROUP ALA 1: for the failure of one of the two sensors. When this occurs, energy metering is impossible and so is not carried out; while metering the volume of vector fluid proceeds normally loading the meter with m^3 of heating.
- ALARM 3 of GROUP ALA 1: removal of the body and protective cover (after breaking the seals). With this alarm all other alarms are disabled, since these are obvious. Metering is clearly not possible.

The triggering of any type of alarm is signalled via output A+, A0 (terminals 50 and 51), which remains closed so long as the alarm status remains: this output is compatible with the alarm inputs of any COSTER electronic device and so can be managed in the same way as any type of site alarm.

17.6 Calculation of flow of vector fluid and of instantaneous power

On the basis of the signal received from the volumetric meters the instantaneous flow in m³/h is calculated and also the instantaneous power in Kw which at that moment is being supplied to the site.

17.7 Recording of the meter readings

The recording of the meter readings is carried out so as to ensure there is absolutely no loss of data.

When the meter is being used to its maximum capacity the four most important meter readings to be recorded are:

- ENERGY HEATING SIDE (MWh)
- VOLUME HEATING SIDE (m³)
- ENERGY COOLING SIDE (MWh)
- VOLUME COOLING SIDE (m³)

All the four meter readings are also recorded as “Total meter readings”: these are four additional values which represent the sum of meter readings from when the meter was first used; they can be compared to the total mileage of an automobile.

The total meter readings cannot be altered in any way since they represent values which regard important fiscal matters.

The meter readings normally displayed can be adjusted, as will be shown in the following section.

The single meter reading is stored in two separate memories: should either of the two memories become corrupted, it is automatically replaced by the other.

Only if both memories should become corrupted simultaneously would the data be lost; the probability of this happening is practically nil, because the two memories are never used at the same moment and the levels of protection against electrical and radio disturbances are at the maximum level required by the standards (see section 11).

17.8 Adjustment of meter readings

The adjustment of all meter readings serves to equalize the readings of external meters to those of the IET 71.. meters. Examples :

- the meter is installed after the volumetric meter installed has totalled the readings. Normally, when the turbine volumetric meter is first installed the plant is started up and the meter starts to measure the volume flowing past it (m³).

IET 71.., when first installed and set in operation, has all its meters set to zero or at the minimum amount necessary for testing. The metering of m³ by the volumetric meter is, therefore, different from the metering of the same m³ by the electronic meter: it is possible to reconcile the two meter readings.

- the meter is installed as a replacement for a pre-existing meter; in this situation also it is useful for the client to have the readings on the new meter which start from those already made by the old one.

The adjustment operation must obviously be protected by a seal, since any alteration would mean different data readings.

The basic data, however, is always stored in the meter and must not be altered in any way, since they are fiscal data ; the next section describes these meter readings in more detail.

In the memories are stored the basic meter readings together with the adjusted values; in this way the true readings are securely safeguarded, as are the adjustment values; the figures to present to the user are the basic meter readings, corrected by the adjustment values.

Furthermore, all data which has undergone any adjustments is recorded, in order to identify errors and intentional tamperings.

17.9 Data storage (DATA LOGGER) of meter readings, power and flow peaks, and errors

The unit incorporates a DATA LOGGER which can store 52 weeks of meter readings and operational data: by this means it is possible to understand, check and if necessary interpolate all the data for a whole year.

- RECORDING METER READINGS: every week (at around midnight on Sundays) a recorded the four fundamental meter readings made up to that moment (see section 17.8) with day and date.

- RECORDING OF POWER & FLOW PEAKS: every week are recorded the values of maximum power and flow reached that week.

The maximum flow of the vector fluid is calculated as the mean over a certain number of minutes (chosen via Telemangement), so as to avoid sudden insignificant peaks; the same criteria are followed for power.

The power peaks are recorded indifferently for heating and for cooling, since it is very easy to understand, on the basis of the season, if reference is to one or the other.

- RECORDING OF ERRORS (ALARMS): each type of alarm (see section 16) is recorded both when it is triggered and when it ceases, with exact date and time. The system records up to 10 of these events; after this it cancels the oldest to leave space for new ones.

Everything having reference to the DATA LOGGER can be set and read via Telemangement C-Bus.

17.10 Overall operating hours

The electronic unit incorporates a meter which sums all the operating hours from the moment in which it leaves the factory; a knowledge of this figure is necessary in order to know the "Age" of the unit.

You can set the number of hours after which the system triggers an alarm (ALARM No. 4 GROUP ALA 2).

Once note has been taken of this alarm and appropriate checks of the system made, a further period is programmed for the alarm.

This period, expressed in hours, is generally the number of years the meter has been in operation; after this period (generally from 5 to 7 years) the standards require the system to be re-calibrated.

17.11 Maximum flow vector fluid

It is possible to enter a value for maximum flow (m³/h) for the vector fluid; when this threshold is exceeded by a certain time (standard: one minute adjustable via Telemangement) ALARM 3 of GROUP ALA 2 is triggered.

17.12 Auxiliary information for various meter readings

With the various meter readings it is possible to associate a certain number of characters which can be entered and read via Telemangement in order to read the data more clearly.

– THERMAL AND/OR REFRIGERATION ENERGY: you can associate 16 alphanumeric characters which represent the identity of the user (names of persons or site).

17.13 Clock

IET 71.. is provided with a universal clock which is essential for recording the times and for assigning the time and date to each DATA LOGGER recording.

In the event of a power failure, the system battery keeps the clock and the rest of the unit in operation; should the module be removed from the base, the clock has its own power reserve for at least 24 hours provided the battery for the whole system is installed in the base.

17.14 Telemangement

The unit is provided with C-BUS (COSTER – BUS SLAVE) for local or remote readout of all the data.

As of firmware version 13, transmission speed is programmable from 1200 to 9600 baud.

Via Telemangement it is possible to set all the parameters except fiscal ones.

– DATA WHICH CAN BE READ & SET VIA C-BUS: all the data processed by the system, all the alarm thresholds, adjustment of the clock, all the information referred to in section 17.13; the cancelling of errors in DATA LOGGER can be carried out after a special enabling, accessible only on request to COSTER technical staff.

– DATA WHICH CAN BE READ & SET ONLY LOCALLY, AFTER BREAKING THE SEAL: this data is considered to be fiscal and so cannot legally be altered except by persons entitled to break and replace the seal. This data comprises: type, weight and position of the volumetric meter for the vector fluid for heating and conditioning, adjustment values for all the meter readings and the alarms for maximum contractual flow and for exceeding the hours of operation before re-calibration.

18. COMPLETE READOUT OF THE UNIT & NON-FISCAL SETTINGS

The complete readout of the unit starts from the simplified readout already described in section 16: for each of the pages M1 ...M.8 there may exist subpages with further information, usually regarding the starting page, and for entering certain non-fiscal data.

To scroll the pages the key is used, while for changing from normal forward scrolling the key is used; this key also increases the data to be entered. The key must be used every time you wish to deviate from normal forward scrolling; it acts rather like a set of railway points.

The deviated sub-menu is shown by the pulsating of the "v v" indices above the page indicators. To change the data in the sub-menus, press the key again: the first figure to be modified starts to flash; by pressing again its value increases; to pass to the next digit press the key **during the flashing**.

To exit directly from the settings page, without continuing with the changes, wait until the flashing ceases (6 seconds) and press .

18.1 Menu meter readings & miscellaneous information

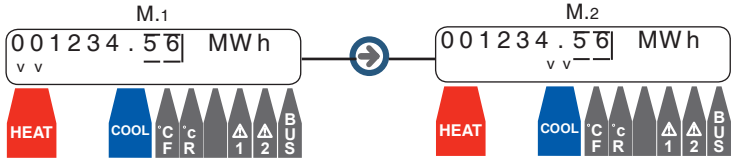

M.1.1

0045678.9 m³
v v

Volume of heating vector fluid metered & if necessary adjusted

M.1.2

00001.234 m³ / h
v v

Instantaneous flow vector fluid heating and/or cooling

M.1.3

000023.45 KW
v v

Instantaneous power heating

M.1.4

000100.00 L / P
v v

L/P = output vol. meter litres per pulse (Max. 1000 l/p)
P/L = output vol. meter pulses per litre (Max. 1000 p/l)

M.1.5

FLO RET
v v

RET = volumetric meter installed on return
FLO = volumetric meter installed on flow

M.1.6

02000.000 m³ / h
v v

m³/h alternates with FMAX = maximum flow threshold above which alarm triggered for maximum flow (Alarm 3 Group ALA 2)

M.1.7

003667.89 MW h
v v

MWh alternates with TOT = total metering of heating energy. Cannot be altered

M.1.8

0056678.9 m³
v v

m³ alternates with TOT = as above but for volume. Cannot be altered

M.2.1

0045678.9 m³
v v

Volume of vector fluid cooling metered & if necessary adjusted

M.2.2

00001.234 m³ / h
v v

Instantaneous flow vector fluid heating and/or cooling

M.2.3

000023.45 KW
v v

Instantaneous power cooling

M.2.4

000100.00 L / P
v v

L/P = output vol. meter litres per pulse (Max. 1000 l/p)
P/L = output vol. meter pulses per litre (Max. 1000 p/l).

M.2.5

FLO RET
v v

RET = volumetric meter installed on return
FLO = volumetric meter installed on flow

M.2.6

02000.000 m³ / h
v v

m³/h alternates with FMAX = maximum flow threshold for triggering alarm for maximum flow (Alarm 3 Group ALA 2)

M.2.7

003667.89 MW h
v v

MWh alternates with TOT = total count of cooling energy. Cannot be altered

M.2.8

0056678.9 m³
v v

m³ alternates with TOT = as above but for volume. Cannot be altered

By pressing at the end of each column you return to the top and you can move to the next column by pressing again. If, on the other hand, having returned to the head of the column you press , you start to scroll the same column again

Remember that on the first pages M1 and M2 you can read the values which may have been adjusted, while on the pages with the measurement units alternating with TOT you read the total values, from the start of the life of the meter.

The default values (factory settings), where present, are in bold type.

18.2 Temperature menu

The menu for temperature of flow & return and for the difference between the two does not have sub-menus.

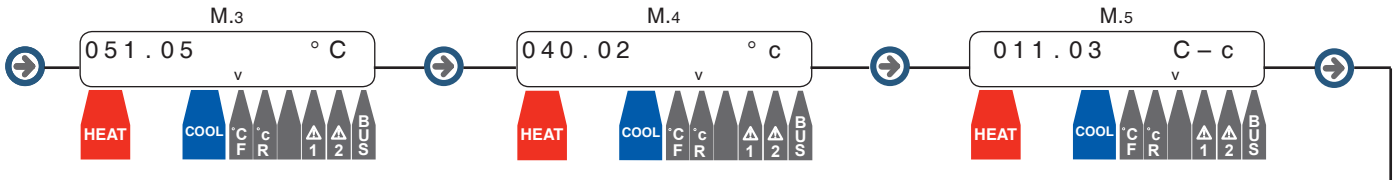

18.3 Menu alarms, clock, date, operating hours, logger alarms & various

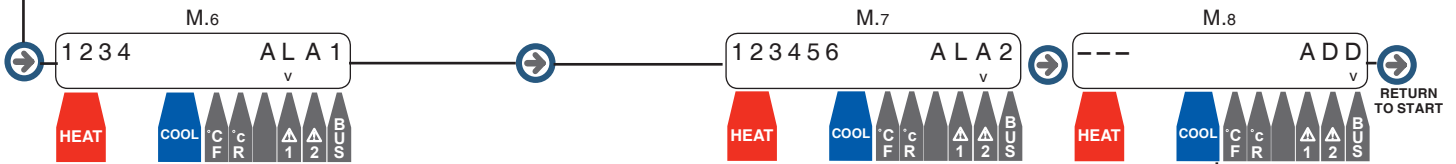

ALA 1 alternates with LOGG = presence of logger (recorder) of the alarms with number indicated: by pressing the two keys at same time for at least 10 seconds this indication is cancelled, but not the data recorded.



Current time in hours, minutes & seconds.

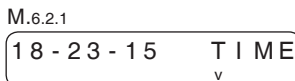

18 (hrs) flashes; adjust with key



23 (min.) flashes: adjust with key

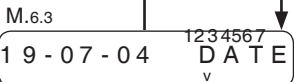

Data as day - month - year

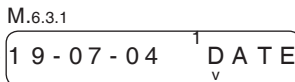

1(day of week) flashes: adjust with key .
1 = Monday; 7 = Sunday



19 (date) flashes: adjust with key



07(month) flashes: adjust with key

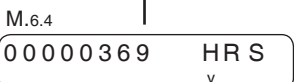

Operating hours of unit from its creation (manufacture)



04(year) flashes: adjust with key



HRS alternating with ALA =no. hours after which alarm for maintenance triggered (Alarm 4 Group ALA 2

RETURN TO HEAD OF COLUMN



ALA 2 alternates with LOGG = presence in logger (recorder) of the alarms with number indicated: by pressing the two keys at the same time for at least 10 seconds this indication is annulled, but not the data recorded



DISPLAY TEST = all segments of display activated to check if operating correctly..



Shows version of software with consequent update C.
- C1 = first update C
- V.XX = version software

RETURN TO HEAD OF COLUMN



RETURN TO START



001flashing = address 10n this page the C-Bus address of the unit is entered. To keep address 1 press key twice.

To adjust press key. Keeping key pressed, the forward speed increases up to a maximum; by releasing key, the address stops removing 10 from the value reached in that moment. By single taps set the correct value, even if it escaped at first try.



To change press key. the modifiable number flashes. Settable values are: 1200, 2400, 4800 and 9600 baud.

RETURN TO HEAD OF COLUMN

The default values (factory settings), where present, are shown in bold type.

19. FISCAL SETTING - STRUCTURE OF PAGES ON THE DISPLAY

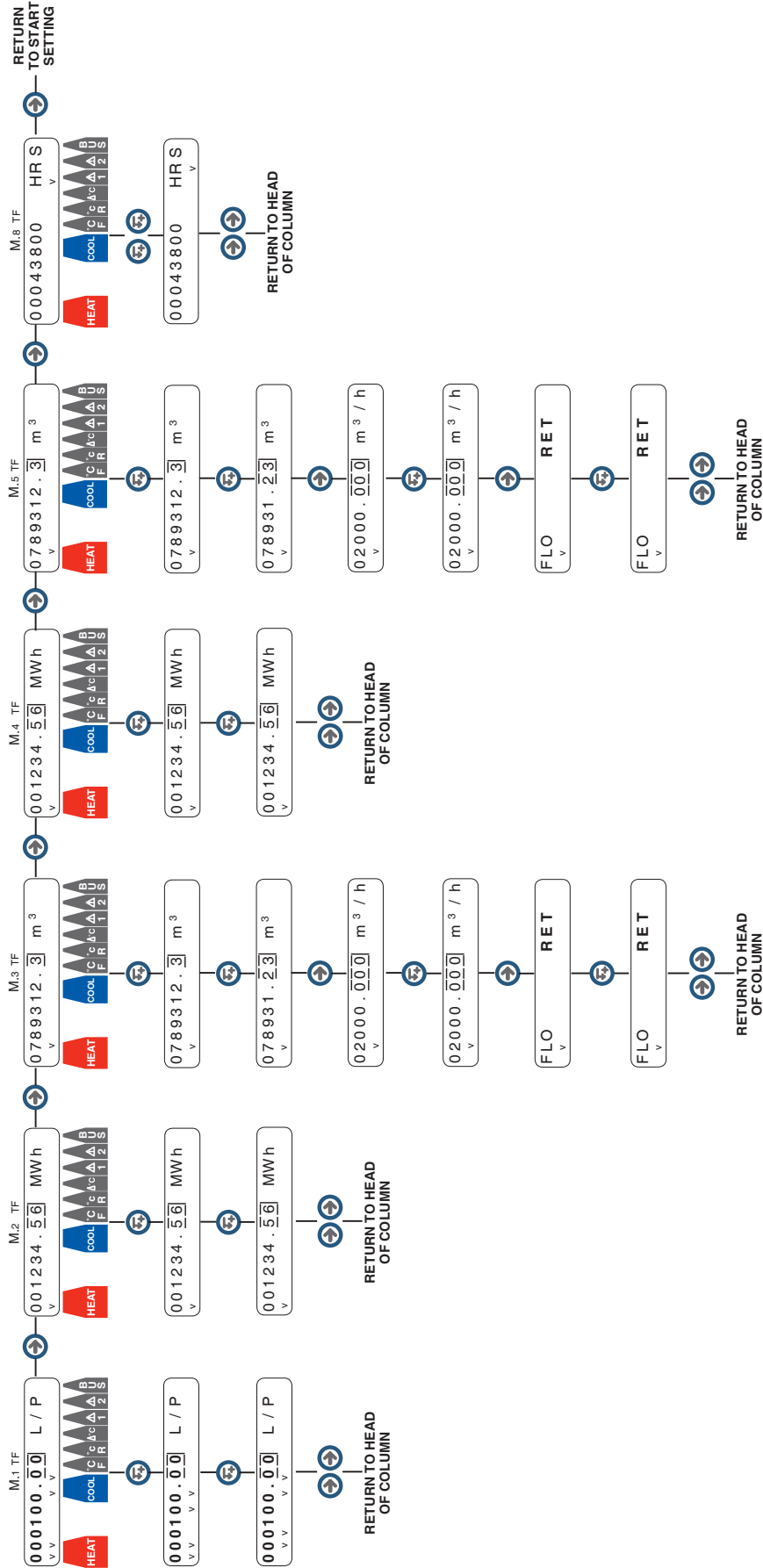

To scroll the menus (and the pages of the sub-menus) use the key To enter sub-menus use the key

20. SETTING FISCAL PARAMETERS & PROGRAMMING ALARMS

The fiscal parameters have a direct influence on the metering of the whole system; in order to change these parameters it is necessary to open the seals on the unit (see section 5) and take certain actions inside the meter. The parameters are:

- TYPE OF OUTPUT, WEIGHT & INSTALLATION POSITION OF THE VOLUMETRIC METER FOR THE VECTOR FLUID FOR HEATING/COOLING.
- To configure the type of volumetric meter for vector fluid, do as follows:**
 - Position SWITCH 7 (see section 20.3)
 - Position JUMPER P4 (see section 9)
- ANY ADJUSTMENTS TO THE FOUR METERINGS.
- THRESHOLD OF MAXIMUM FLOW FOR THE VECTOR FLUID (if the relative alarm is required).
- THRESHOLD NUMBER OF OPERATING HOURS BEFORE CARRYNG OUT MAINTENANCE & REPLACEMENT OF BATTERY.

20.1 Dip switches for the settings

By removing the electronic unit and turning it upside down you can see at the bottom on the right the dip switches for the settings

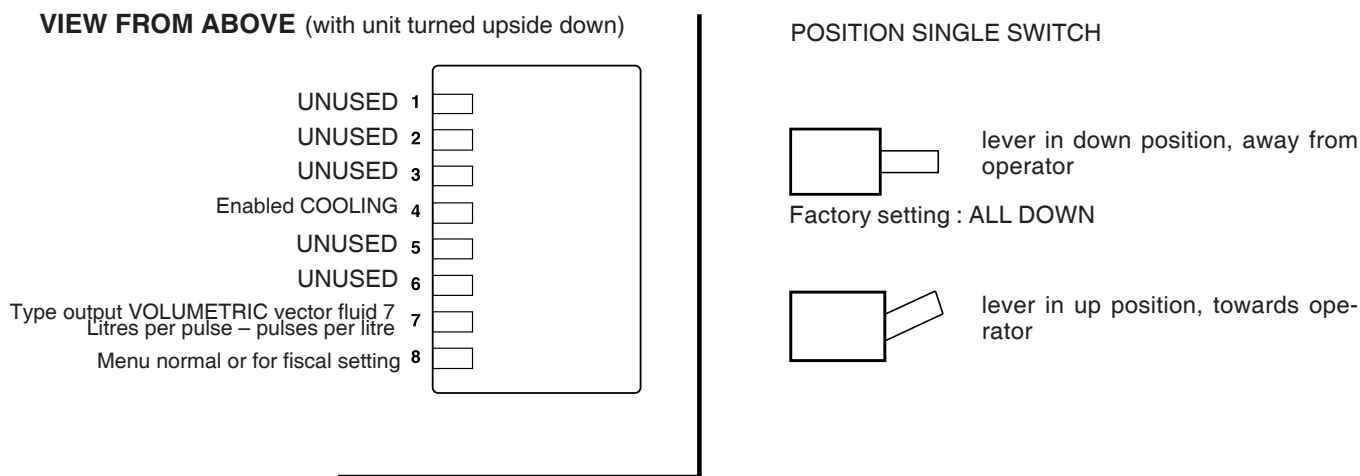

20.2 Switch number 4: "Enabling COOLING"

With this switch you can decide whether to have metering of heating only (calories) or metering of heating (calories) and, at the same time, of cooling (frigories), as described in section 16.4.

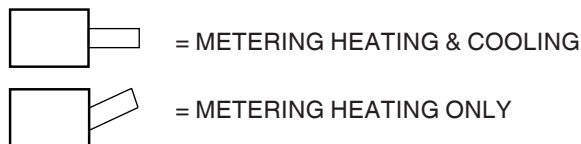

20.3 Switch number 7: choice of "volumetric meter for vector fluid, heating and/or cooling between output LITRES PER PULSE & PULSES PER LITRE"

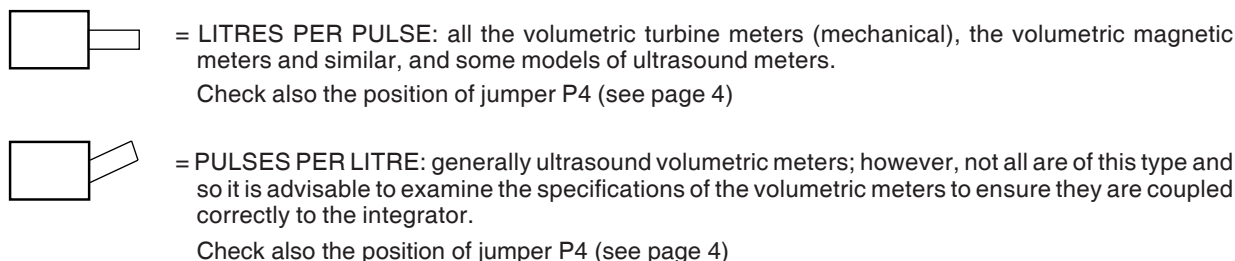

20.4 Switch number 8: choice between “normal use menu” and “menu for fiscal settings”

Using this switch you can enter the menu for fiscal settings

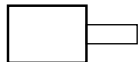

= NORMAL OPERATING MENU: this is the menu for the normal use of IET 71.. ; it does not permit adjustments to fiscal data.

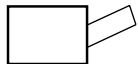

= MENU FOR SETTING FISCAL DATA: with this menu you can enter and adjust all the data previously described as fiscal: for the purpose of setting of this data it is necessary to go to the normal menu in order for the unit to operate correctly and protect the fiscal data entered. Once the MENU FOR SETTING FISCAL DATA has been selected, replace the module on its base and keep pressed at the same time the two buttons and for at least 10 seconds; in this way you enter the fiscal settings menu

20.5 FISCAL SETTINGS FOR HEATING SIDE

The setting of the pulse weight has been first placed first in the sequence of settings because it must be carried out before the alignment. If the pulse weight is altered it is also necessary to check the setting (if present) of the alignment.

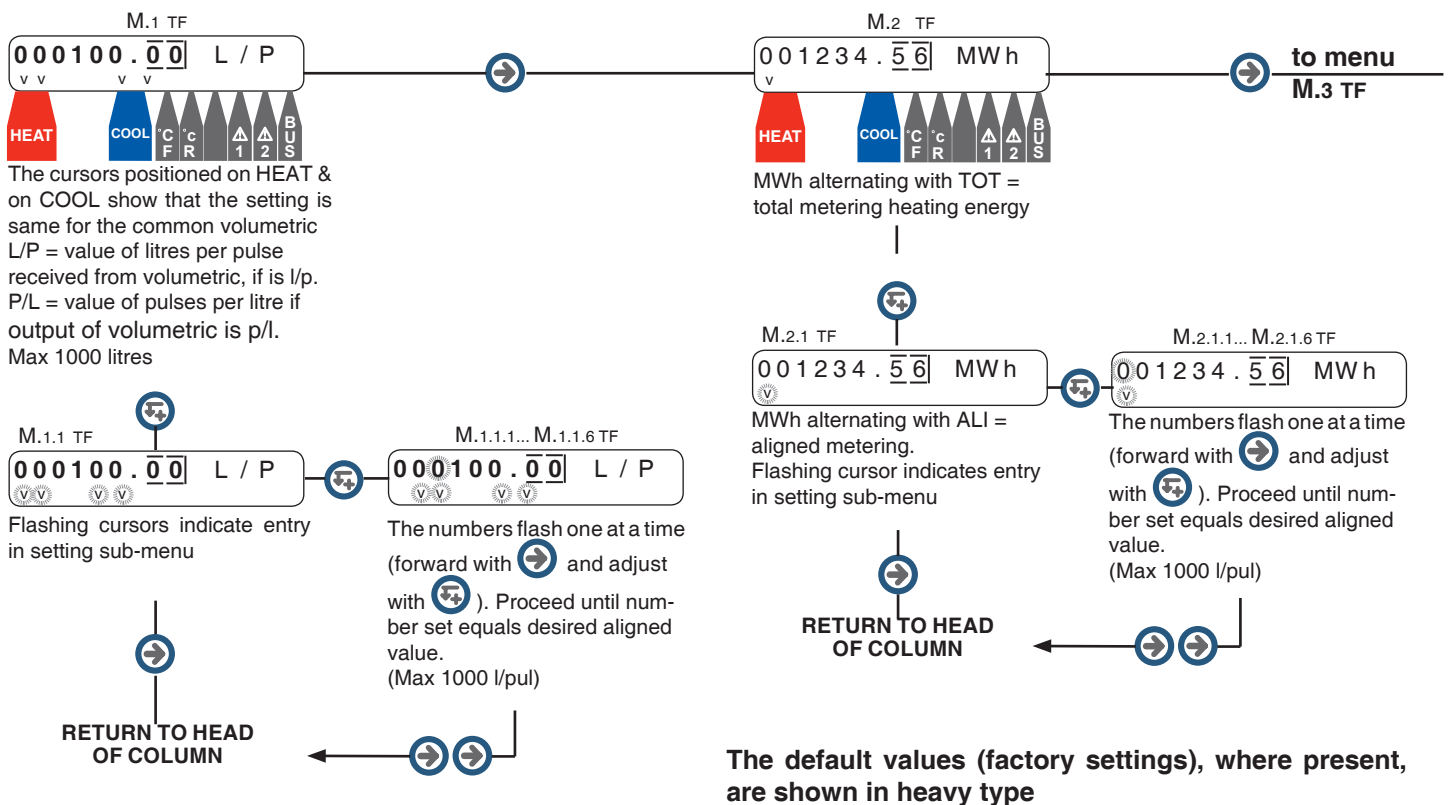

PROTECTION OF FISCAL DATA :

When you enter in “MENU FOR SETTING FISCAL DATA”(switch 8 lever up) you can access the amendment of these data by keeping pressed for at least 10 seconds the two switches (as seen above).

If the switches are not used for at least 15 minutes you exit the menu, returning to the first page (M.1) of the normal menu. To re-enter the setting menu it is necessary to detach the module from its base, re-insert it and press again the two switches for 10 seconds.

Once the fiscal settings have been completed it is necessary to reset switch number 8 in the position “NORMAL OPERATING MENU” (switch down),

re-insert the module on its base and replace all the seals so as to avoid tampering with the meter.

The operations just described serve to safeguard the fiscal data even should the operator inadvertently leave the dip switch number 8 in the up position.

Fifteen minutes after the end of the fiscal settings, even if the operator re-inserts the module and replaces the seals but forgets to lower dip switch 8, all the fiscal data are protected, and in order to change them it is necessary to break the seals in order to extract and replace the module on its base.

The default values (factory settings), where they exist, are shown in bold type.

20.6 FISCAL SETTINGS COOLING SIDE & SETTING ALARMS

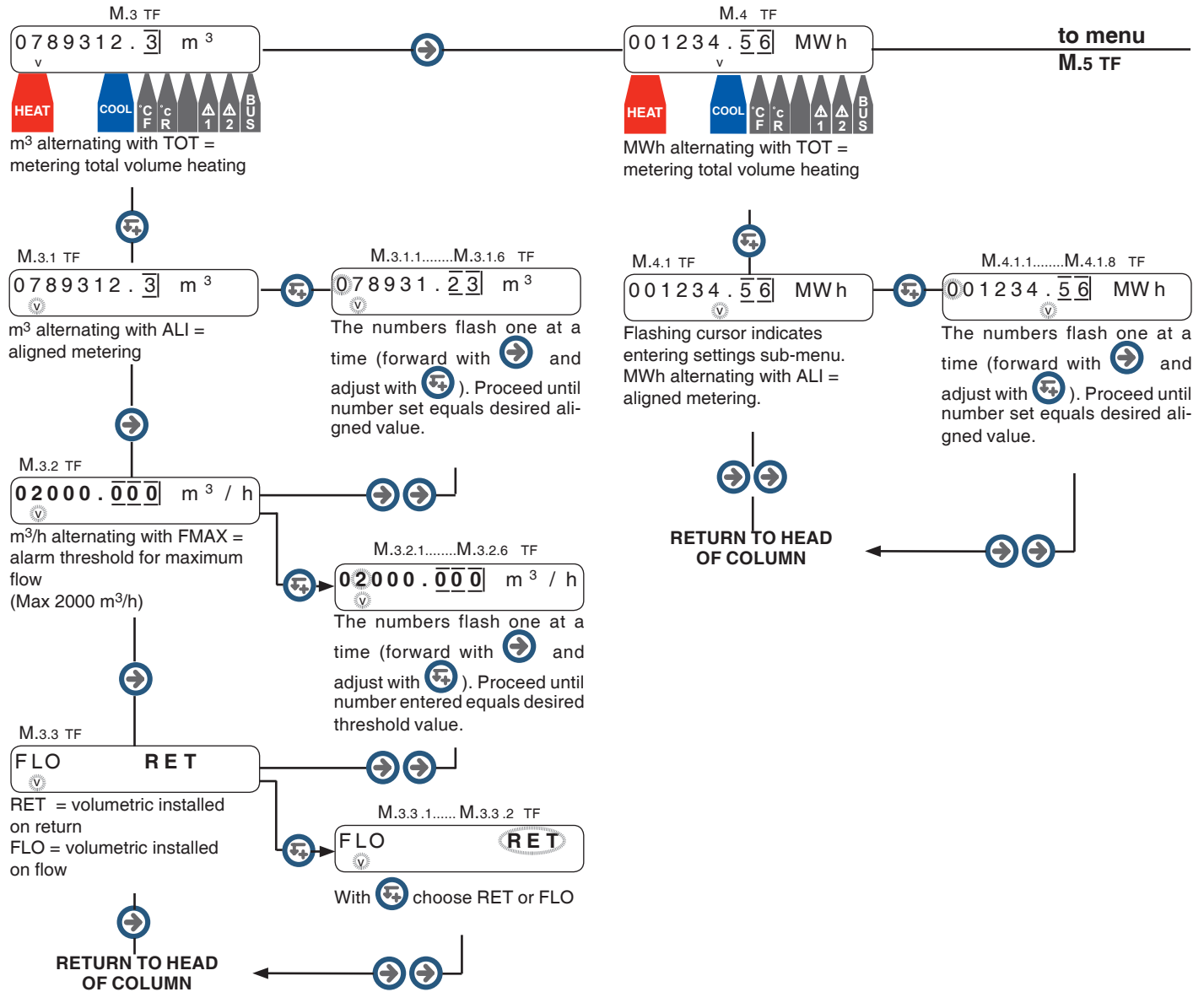

The default values (factory settings) are shown in heavy type

20.7 FISCAL SETTINGS COOLING – OVERHAUL ALARM

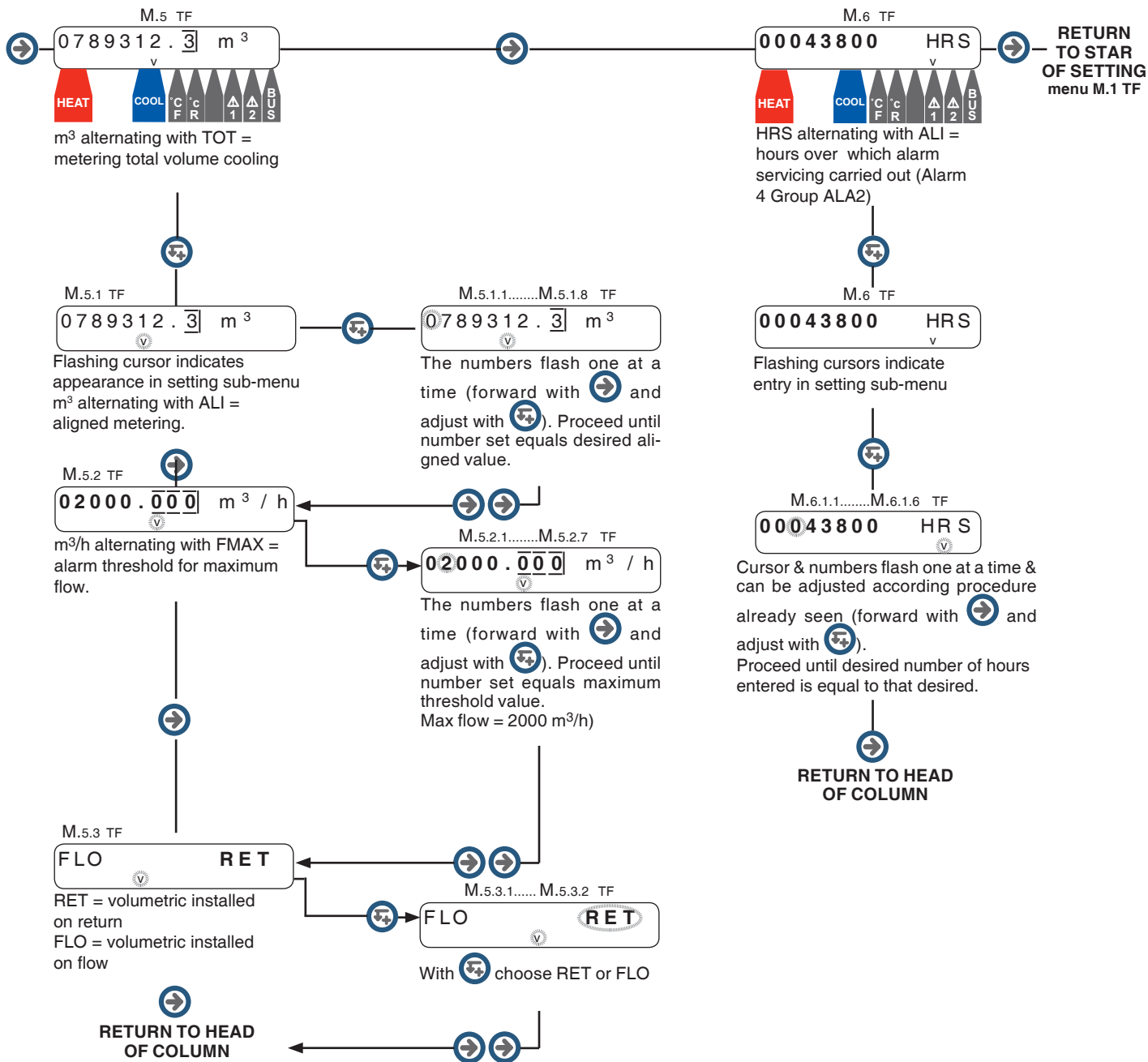

OBSERVATIONS : The pages regarding the calibration of the volumetric meter are repeated on the cooling side, for ease of use. The calibration operations can be made either on the heating or cooling sides.

21. TESTING

Once the mechanical and electrical installation of the unit has been completed, it is necessary to carry out testing in order to ensure that the system meters and processes the readings correctly. Inefficient testing can compromise the metering for a whole season, since an error in the metering systems becomes evident only after a considerable time, generally at the end of the season when consumption has already taken place.

21.1 Checking flow sensor (labelled _a) test

Read the temperature on page M.5 in section 16 and check that the value shown is a reasonable one.

21.2 Checking return sensor (labelled _b) test

Read the temperature on page M.6 in section 16 and check that the value shown is a reasonable one.

21.3 Checking the difference between the flow and return temperatures

With this test it is possible to know whether the two sensors have been interchanged.

– HEATING ZONE: when the plant is in operation the difference should have a positive value; if not, the sensors have probably been inverted.

With the plant switched off the temperature difference can be positive or negative: check the installation of the sensors by removing the sensor from the pocket, warming it with the hands and checking the values indicated.

– CONDITIONING ZONE (cooling): when the plant is in operation the difference should have a negative value; if not, the sensors have probably been inverted.

With the plant switched off the temperature difference can be positive or negative: check the installation of the sensors by removing the sensor from the pocket, warming it with the hands and checking the values indicated.

If the sensors have been interchanged, when heating only is metered the readings will not be affected; whilst when heating and cooling are metered the relative measurements will be interchanged.

21.4 Checking the operation of the volumetric meter for the vector fluid

In order to be certain that the test has been carried out correctly it is necessary for the heating and/or conditioning plant to have the vector fluid circulating; any other type of simulated testing can hide certain problems.

Have the fluid circulating for a certain period of time and check that the volume metered on page M.1.1 and on page M.2.1 changes by a reasonable amount.

BE VERY CAREFUL THAT THE FEATURES OF THE VOLUMETRIC METER FOR THE VECTOR FLUID ARE REPORTED ACCURATELY AS TO TYPE AND VALUE IN THE FISCAL SETTINGS; AN ERROR IN THESE PARAMETERS WILL COMPROMISE THE READINGS.

If the plant is switched off because the season is warm, switch on at least the pumps for the vector fluid. It is advisable always to check at the start of the season that the metering is functioning correctly.

21.6 Testing alarm output

Trigger any alarm (the simplest way is to disconnect a sensor) and check that the output really does respond, once it has been connected to a receiver of any type (e.g. standard alarm inputs for COSTER electronic devices).

The testing can also be carried out using a normal tester, exchanging the probes if necessary, and bearing in mind that the output is of the OPEN COLLECTOR type.

22. DATA WHICH CAN BE SET ONLY VIA TELEMAGEMENT

Certain functions with their respective parameters can be set and adjusted only via Telemagement using a local or remote PC and by an administrator authorised to operate at the highest level of the SWC 701 program.

22.1 Alarm for absence of flow with temperature difference in progress

This alarm is in the GROUP ALA 1, number 4 (see page M.8, section 16).

As seen previously, this alarm is useful when, in the face of an existing difference in temperature between flow and return, the meter for the flow of the vector fluid does not send any pulse for a certain period of time.

The factory setting for the temperature difference is set at **5°C** (absolute value, since this difference can be positive or negative depending on whether heating or cooling is in progress).

The threshold time is **24 hours** (factory setting).

22.2 Lockout of cooling energy metering when the flow temperature exceeds a certain value

This function blocks energy metering for summer conditioning when the flow temperature is above a certain value (factory setting: **23°C**); this function is also enabled at the factory.

The purpose of this function is as follows:

If the cold generator (CHILLER) is switched off for some reason and the circulation pump continues to operate, it may happen that the flow temperature rises and at the same time the return temperature also rises, and to a greater extent, since it is heated by a larger number of consumers; the room is warm because there is no longer conditioning. Without this function the refrigeration energy, which the rooms give up to the conditioning system in the interval between raising the temperature and reading it, is metered.

22.3 Calculation interval for the flow & the maximum power for the data logger

In section 17.9 is illustrated the recording of power and flow peaks which are recorded in the DATA LOGGER every week. The base time for the calculation of these two values (factory setting: **15 minutes**) can be adjusted.

22.4 Setting dates of GMT and BST

The dates of GMT and BST can be set automatically by the unit (factory setting: **automatic**) or by hand.

22.5 Auxiliary output for forwarding alarms and/or remote control

This auxiliary output (A) can be used for forwarding alarms and/or as a remote control operated via Telemagement.

The functions which can be programmed via Telemagement are:

- ALARM ONLY: the output is enabled in the presence of one or more alarms (see section 16) chosen as required.
- REMOTE CONTROL ONLY: the output is enabled or disabled by the Telemagement program.
- ALARM + REMOTE CONTROL: the sum of the two preceding functions.
- UNUSED: the output is not used.

The most common use of this output is that of switching off heating to a user of a zoned plant who is in arrears.

Amendment to data sheet

Date	Revision No.	Page	Section	Description amendment	Firmware version	Software version
03.02.06 AM		4	9. ELECTRICAL CONNECT.	Explanations of the power output, terminal G, for ultrasound or similar sensors.		
28.03.07 AM	01	various	various	Pages regarding WEIGHT PULSES have been positioned earlier.		
21.02.08 AM	02	4 5 17	9. ELECTRICAL CONNECT. 10.3 Volumetric meter for... 20. SETTING FISCAL PARAMETERS...	Changeover to C1 version: Introduce the high-resolution jumper (Z6) Introduce the selection jumper of volumetric litres/pulse type or pulses/litre (P4)		
26.09.08 AM	03	5	10. WIRING DIAGRAM	Update wiring diagram		
16.07.09 VM	04	2 5 6 6	4. TECHNICAL DATA 10.1 Connection of the temperature... 12. LABELING OF METERS 13 and 14	Directive MID 2004/22/EC		
25.11.09 VM	05	6	10.7 and 10.8	Application example for the use of impulse relay in direct and indirect mode		
18.01.10 MM	06	various	various	Addition of the option of communicating at different speeds (from 1200 to 9600 baud)	≥ 13	