

COMPENSATING CONTROLLER

OPTIONAL

C ← BUS

C ← RING

XTE 600 C1 Eng.



- **Digital controller for boiler house with annual programming :**
 - compensated control of heating zone ;
 - control of DHW temperature with control DHW pump;
- **Communication systems :**
 - **C-Ring** for exchanging data between local controllers.
 - **C-Bus** : XTE 600 Telemangement optional;
to enable Telemangement use the “C-Bus Plug-in” type “C-Bus Plug-in” type **ACB 468 C1 or later**, to be ordered separately as accessory.
- **Power supply 230 V AC (or 240 V AC for UK market); DIN rail mounting.**

1. APPLICATION

XTE 600 is designed for the compensated control of central heating zones in :
 – commercial and public buildings
 – schools;
 – residential complexes

2. FUNCTIONS

The principal functions of XTE 600 are :

- Compensated control of heating zone :
 - three-wire control of valve actuator or On-Off in one or two steps;
 - optimisation of start and stop times of plant ;
 - control plant pump by current programme of timed events with switching off delay;
 - frost protection;
 - minimum and maximum limits of flow temperature;
 - correction of heating curve origin;
 - self-adjusting;
 - Eco Off
 - Control of stored DHW temperature :
 - control of DHW pump by sensor or only by programme of timed events;
 - priority function and antibacteria ;
 - Timed programming: twentyfive 24Hour programs & two 7Day periods
 - Programming with dates : twentyfive holiday periods; winter season; special period.
 - Summer plant exercise of valve and pumps.
 - Automatic changeover GMT/BST.
 - Metering of degree-days.
 - Remote control for modifying current programme.
 - Four On-Off inputs for signalling status or alarm.
 - Alarms for short or open sensor circuits and for incorrect operation of plant and controllers.
 - C-Ring interface for local sharing of data with other controllers.
 - Optional C-Bus transmission of data with local PCs or remote Telemangement PC.
- To enable data transmission and Telemangement use the “C-Bus Plug-in” type ACB 468 C1 or later.**
To communicate locally with a PC use the test Plug-in type ACX 232

3. SENSORS, REMOTE CONTROL & ACCESSORIES

No.	Description	Type	Sensing element	Code	Data sheet
1	Heating flow temperature sensor contact ¹⁾	SCH 010	NTC 10 kΩ	B1	N 130
1	Outside temperature sensor	SAE 001	NTC 1kΩ	B2	N 120
1	DHW temperature sensor immersion ²⁾	SIH 010	NTC 10 kΩ	B5	N 140
Options					
1	1) Immersion temperature sensor	SIH 010	NTC 10 kΩ	B1	N 140
1	2) Cable-type temperature sensor	SAF 010	NTC 10 kΩ	B5	N 145
Accessories					
1	Ambient temperature sensor	SAB 010	NTC 10 kΩ	B3	N 111
1	Boiler anticondensing temperature sensor immersion	SIH 010	NTC 10 kΩ	B4	N 140
1	Flue gases temperature sensor	STF 001	PT 1 kΩ	B6	N 165
1	Accessory for connecting 4...20 mA active sensor	ASA 420	–	B7	–
1	Remote control for modifying current programme	CDB 300	–	R	N 710
Accessory for Telemangement					
1	Plug-in for communicating via C-Bus	ACB 468 C1	–	–	T 433

4. TECHNICAL DATA

• Electrical

Power supply	230 V AC ± 10%
	or 240 V AC for UK market
Frequency	50 ... 60 Hz
Consumption	5 VA
Protection	IP40
Radio disturbances	VDE0875/0871
Vibration test	with 2g (DIN 40 046)
Voltage-free output contacts:	
maximum switching voltage	250 V~
maximum switching current	5 (1) A
Construction standards	Italian Electro. Committee (CEI)
Storage data in memory	5 years
Software	Class A

• Mechanical

Case	DIN 6E module
Mounting	DIN 35 rail
Materials:	
base	NYLON
cover	ABS
Ambient temperature:	
operating	0 ... 45°C
storage	- 25 ... + 60°C
Ambient humidity	Class F DIN 40040
Dimensions	105 x 115 x 71.5
Weight	0.6 kg

• Programmes & periods

24-hour programmes	1 ... 25
24-hour events	2 ... 6
7-day programmes	0 ... 2
Holiday programmes	0 ... 25
Special period	1
Remote extension period	0 ... 3 ... 72 h

• Measurement ranges

Flow temperature	0 ... 99 °C
Outside temperature	- 30 ... + 40 °C
Ambient temperature	0 ... 30 °C
Anticondensing temperature	0 ... 99 °C

• Heating

Flow temperature :	
radiators	40 ... 70 ... 99 °C
fan coils	40 ... 80 ... 99 °C
panels	20 ... 40 ... 50 °C
minimum limit	1 ... 99 °C
maximum limit	1 ... 99 °C
Design outside temperature	- 30 ... - 5 ... + 20 °C
Correction curve origin	20 ... 40 °C
Boiler anticondensing temperature	0 ... 50 ... 99 °C
Valve run time	30 ... 630 ... 3,600 s
Delay switching off pump	2 ... 30 ... 60 minutes
Ambient authority	0 ... 20 °C/°C
Mode temperatures :	
5 Normal ambient	0 ... 19-21 ... 30 °C
2 Setback ambient	0 ... 14-16 ... 30 °C
Frostprot ambient	0 ... 6.0 ... 30 °C
Remote extension ambient	0 ... 21.0 ... 30 °C
2 Flows water	0 ... 20-30 ... 99 °C
Optimisation operating times :	
start inertia	0.00 ... 1.00 ... 7.45 h
"Normal" optimisation limit	0.00 ... 2.00 ... 12.00 h
"Holidays" optimisation limit	0.00 ... 10.00 ... 40.00 h
boosting	0.0 ... 3.0 ... 10.0 °C
reduction ambient temp. on optimum stop	0.00 ... 0.5 ... 3.5 °C
time constant	1 ... 48 ... 255 h

• Control DHW

Temperature	0 ... 50.0 ... 99.0°C
Differential	0.5 ... 5.0 ... 30.0°C
Increase C-Ring over desired DHW temp.	0 ... 5.0 ... 50.0 °C

• Telemangement

Speed C-Bus chosen from **1200**, 2400, 4800, 9600 bauds

Alarms (setting by PC):

Attempts send alarms	1 ... 5 ... 255
Interval between alarm transmissions	2 ... 10 ... 255 min.
Threshold diff. flow temp. (B1)	0.5 ... 5 ... 99 °C
Delay diff. flow temp.	2 ... 30 ... 255 min.
Threshold diff. DHW temp. (B5)	0.5 ... 5 ... 99 °C
Delay diff. DHW temp.	2 ... 30 ... 255 min.
Threshold diff. ambient temp. (B3)	0.5 ... 1 ... 30 °C
Delay diff. ambient temp.	2 ... 30 ... 255 min.
Max. temperature flue gases (B6)	1 ... 500 ... 510 °C
4 ... 20 mA sensor, min. or max. (B7)	4 ... 12 ... 20 mA

WARNING: In the presence of electrical disturbances the output controls of XTE 600 may change status but this will be restored automatically.

5. OVERALL DIMENSIONS

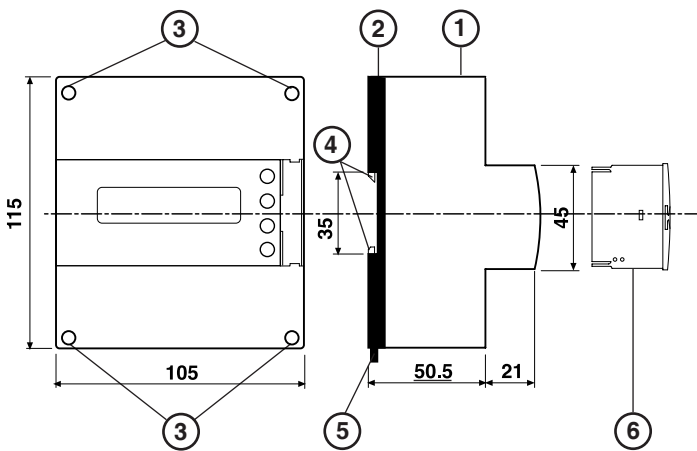

- 1 - Protective cover for electronic components
- 2 - Base with transformer, relay & terminal blocks
- 3 - Screws for fixing cover- base
- 4 - DIN rail securing elements
- 5 - DIN rail release lever
- 6 - Plug-in for C-Bus communication

6. FACIA

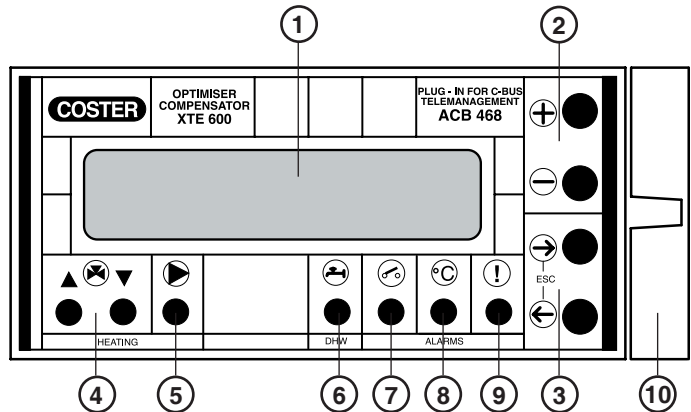

- 1 - Two-line backlighted alphanumeric display
- 2 - + and - operating keys
- 3 - ← and → operating keys
- 4 - Valve control LEDs
- 5 - Plant pump control LED
- 6 - DHW pump control LED
- 7 - On-Off alarms LED
- 8 - Measurement alarms LED
- 9 - Controller fault alarm LED
- 10 - Plug-in type ACB 468 C1 for C-Bus communication

7. SCHEMATIC & WIRING DIAGRAM

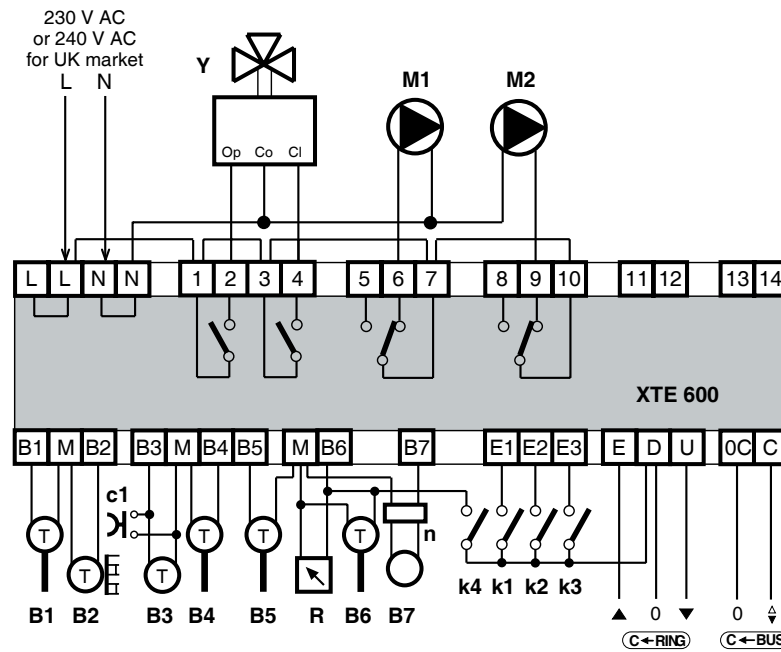

- B1 – Heating zone flow temp. sensor
- B2 – Outside temp. sensor
- B3 – Ambient temp. sensor
- B4 – Anticondensing temp. sensor
- B5 – DHW temp. sensor
- B6 – Flue gases temp. sensor (as alternative to "R")
- B7 – 4 ... 20 mA active sensor
- c1 – Remote extension switch
- k1...3 – On-Off alarm contacts
- k4 – On-Off alarm contact (as alternative to "R")

- L – Line 230 V AC (or 240 V AC for UK market)
- N – Neutral
- M1 – Heating pump
- M2 – Auxiliary circuit pump (DHW)
- R – Ambient remote control (as alternative to B6 and k4)
- Y1 – Heating valve
- n – Convertor cable for connection of active sensors 4...20mA (ASA 420)
- C-Bus – Transmission data via Telemangement; C-Bus is enabled using the Plug-in type ACB 468 C1
- C-Ring – Data transmission between controllers

8. SITING OF CONTROLLER & SENSORS

8.1 Controller

The controller must be sited in a dry space which meets the permitted ambiental conditions shown under 4.TECHNICAL DATA. If positioned in a space classified as "Dangerous" it must be enclosed in a cabinet for electrical apparatus constructed according to the regulations in force for the class of danger involved. It can be installed on a DIN rail or in a DIN modular enclosure.

8.2 Plant flow temperature sensor B1

With plant pump on flow it must be installed downstream of this ; with pump on return it must be installed at least 1.5 meters downstream of regulating valve.

8.3 Outside temperature sensor B2

This must be installed outside the building, on the north or north-west side, at least three meters from the ground and protected from direct sunlight, and as far as possible from windows, doors, chimneys or other possible direct thermal disturbances.

8.4 Ambient temperature sensors B3

This must be installed at a point which represents the average temperature of a representative space, at a height of 1.5 ... 1.6 metres from the floor, on an internal wall as far as possible from windows, doors and sources of heat ; corners, shelving and curtains must be avoided.

8.5 Boiler anticondensing sensor B4

Can be used only if the boiler is fitted with an anticondensing pump and must be installed on the return pipe of the boiler between the anticondensing pump connection and the boiler itself.

8.6 DHW temperature sensor B5

This must be installed on the DHW tank, preferably on the lower part (1/3 height) using cable-type sensors for deep pockets.

9. WIRING

Proceed as follows :

- Separate base and cover
- Mount base on DIN rail and check that securing elements (5.4) hold it firmly in place.
- Carry out wiring according to the diagram and in observance of the relevant regulations in force, and using cables of :
 - 1.5 mm² for power and relay control outputs
 - 1 mm² for sensors and remote control
 - 1 mm² for C-Bus and C-Ring. For wire length limits please see technical data sheets T 021 and T 022
- Reposition the cover on the base / terminal block and fasten with the 4 screws supplied (5.3).
- Check that voltage is correct and supplied by the dedicated auxiliary line, measuring it upstream of the protection (circuit breaker, fuse...).
- Power up the device.

You are advised not to insert more than two cables in a single terminal of the controller and if necessary to use external junction boxes.

10. EXAMPLES OF INSTALLATIONS

10.1 Compensated control of heating zone by control valve, with DHW at constant value.

26.6

Configuration: Control : VALVE
Time : 630 sec

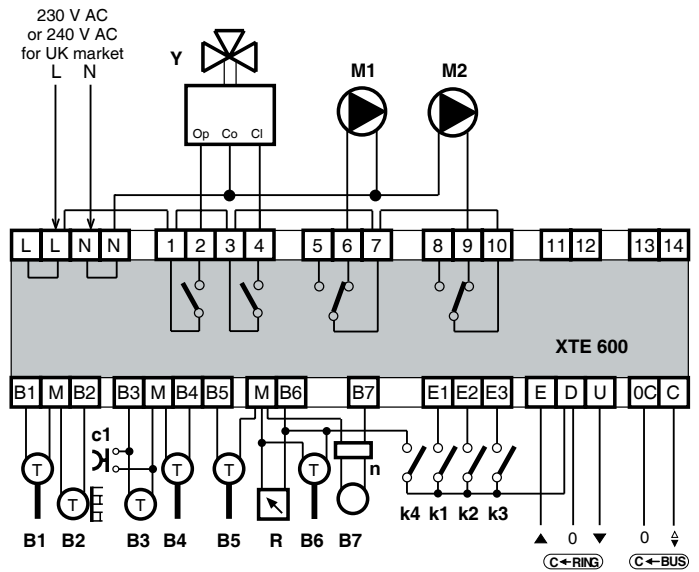
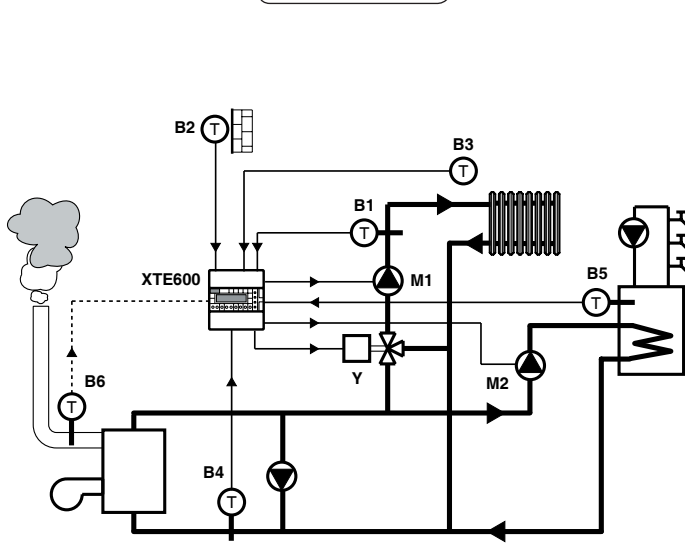

10.2 Compensated control of heating zone by control two-stage burner.

26.6

Configuration: Control : ON-OFF
Different : 10.0c

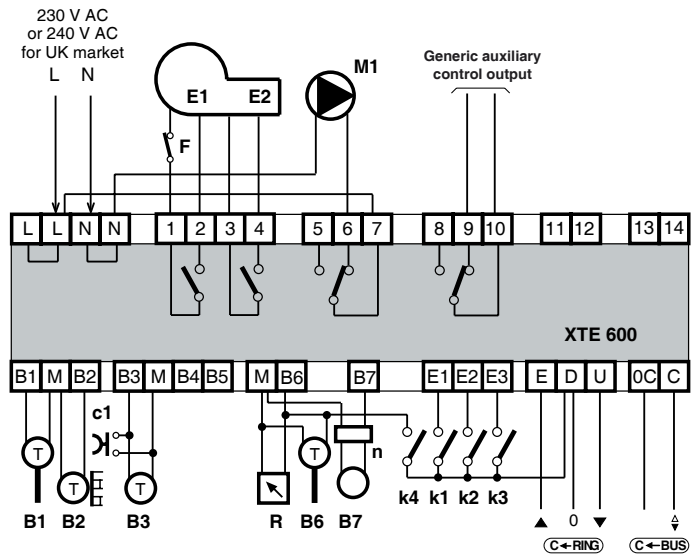
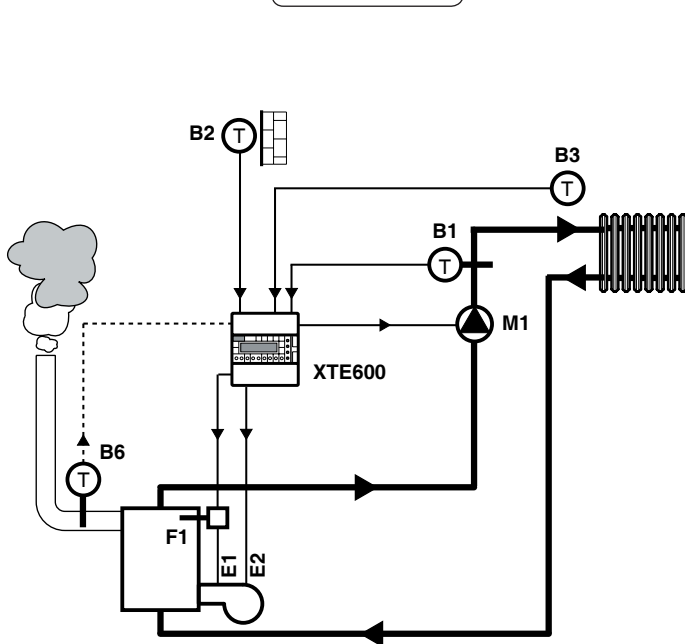

- B1 – Zone flow temp. sensor
- B2 – Outside temp. sensor
- B3 – Ambient temp. sensor
- B4 – Anticondensing temp. sensor
- B5 – DHW temp. sensor
- B6 – Flue gases temp. sensor (as alternative to "R")
- B7 – Active sensor 4 ... 20 mA
- c1 – Remote extension switch
- E1 – 1st stage burner
- E2 – 2nd stage burner
- F – Boiler thermostat

- k1...3 – On-Off alarm contacts
- k4 – On-Off alarm contact (as alternative to "R")
- L – Line 230 V AC (or 240 V AC for UK market)
- N – Neutral
- M1 – Heating pump
- M2 – DHW pump
- R – Ambient remote control (as alternative to B6 and k4)
- Y1 – Heating control valve
- n – Converter cable for connection of active sensors (4...20mA)
- C-Bus – Transmission telemanagement data (Plug-in ACB 468 C1)
- C-Ring – Exchange data between controllers

11. COMMUNICATION

11.1 C-Ring : communication between controllers (for detailed information please see technical data sheet T 022)

XTE 600 controller can be **“Primary”** or **“Secondary”**.

In the C-Ring the following signals are transmitted :

- permission to operate as **Slave** controllers
- value of the **outside temperature** (use of a single sensor for several controllers)
- value of **flow temperature** requested by zone controllers; used by “PRIMARY” controller for regulation temperature boilers (if scheduled).
- **DHW priority** and/or **anticondensing** = closure valves heating zones with modulating control action.

26.3
CRing connection
NO

- NO = connection to C-Ring not scheduled
- YES = connection to C-Ring scheduled
- SECONDARY= connected to C-Ring as SECONDARY controller

11.2 C-Ring wiring diagram

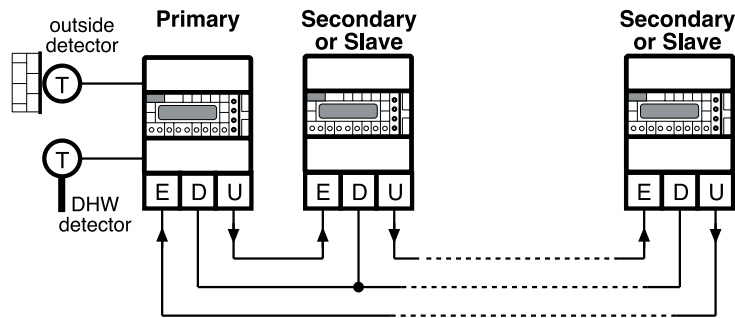

12. C-BUS COMMUNICATION

12.1 C-Bus communication for telemanagement (for detailed information please see technical data sheet T 021)

XTE 600 provides :

- remote Telemanagement by when enabled by **C-Bus Plug-in type ACB 468 C1**
- local communication (e.g. setting via PC) when enabled with Test **Plug-in ACX 232**

Telemanagement is bidirectional, with one or more local PCs and/or the remote central PC via PSTN.

Local communication is direct to a portable PC to be connected directly to the unit.

From PC or PCs it is possible to display and/or change :

- the data and values entered on display pages of the controller and those of configuration dedicated exclusively to telemanagement (see 4. TECHNICAL DATA)
- operational status of plant components (pumps, auxiliaries in general)
- acquire alarms coming from boiler plant
- read the measurements of the sensors (temperatures : outside, flow, boiler, etc)

12.2 C-Bus electrical connection for local or remote Telemanagement

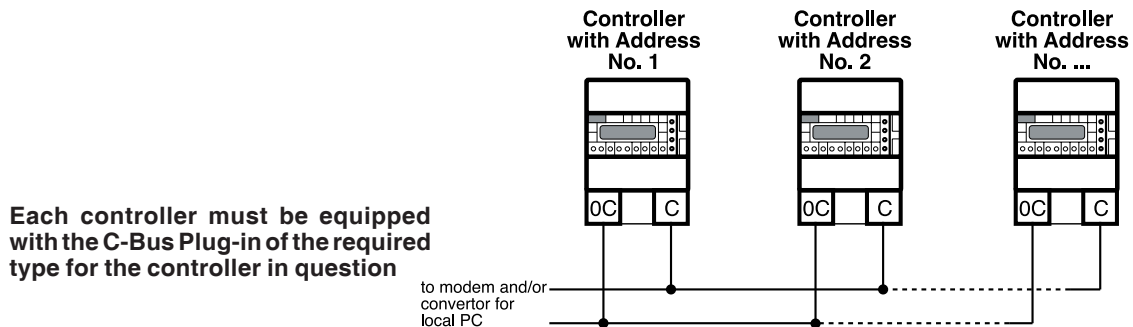

Each controller must be equipped with the C-Bus Plug-in of the required type for the controller in question

12.3 Connection to PC for local communication via test Plug-in ACX 232

Extract the C-Bus Plug-in and insert the test Plug-in ACX 232; use a standard cable to connect the RS232 plug to the PC (the cables are included in the “CONVENIENCE KIT”.

If the PC has only USB inputs use a standard RS232 to USB conversion cable.

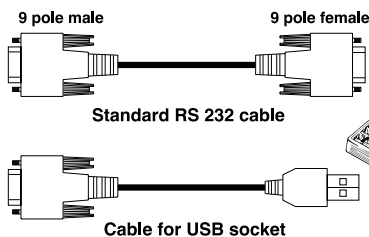
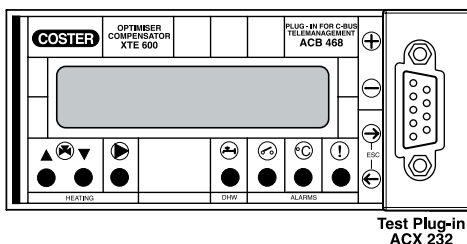

ACCESSORIES:

- Test Plug-in = **ACX 232**
- Convenience kit = **KIT RS 232**

The “Convenience kit” contains the 2 cables & other useful accessories.

- Observations :**
- Before communicating, ensure that the address entered in the controller is the address with which you wish to communicate via PC.
 - It is advisable to use a portable PC powered by battery with the connection to 230 volts unplugged (or 240 V AC for UK market), since the earth (0 volts) of the controller is connected to that of the RS 232 and so to that of the PC. By connecting the two earths together you could have dispersed currents, if the earths have not been well made and if the PC has its 0 volt connected directly to the central pole of the plug (as is usual)

13. OPERATION

XTE 600 is a digital controller with microprocessor for :

- compensated control, with or without ambient authority, of a heating zone. Three-wire control of motorised valve or On-Off of single- or two-stage burners and On-Off of circulation pump.
- control of a temperature at fixed point (or a timed events programme) of a secondary circuit (eg DHW). On-Off control of a plant component.
- the acquisition of status and / or alarms regarding plant components

To configure the controller, please see sections "Sequence of display pages"

14. HEATING ZONE

14.1 Type of heat emitters

26.1

**Heat emitters
RADIATORS**

The controller must be configured according to type of heat emitters used :

- Type heat emitters : RADIATORS
PANELS
FAN COILS

14.2 Heating curve

The flow temperature requested by the controller (sensor B1) is modified in relation to the outside temperature (sensor B2 or value transmitted via C-Ring) and by the heating control curve . The controller compares the actual value of the flow temperature with that corresponding to the curve, and, in the event of a difference, regulates with PI control action (pre-set proportional band Pb and integral time It), the motorised valve to eliminate it.

The heating control curve, having reference to a desired ambient temperature of 20 °C, is established by :

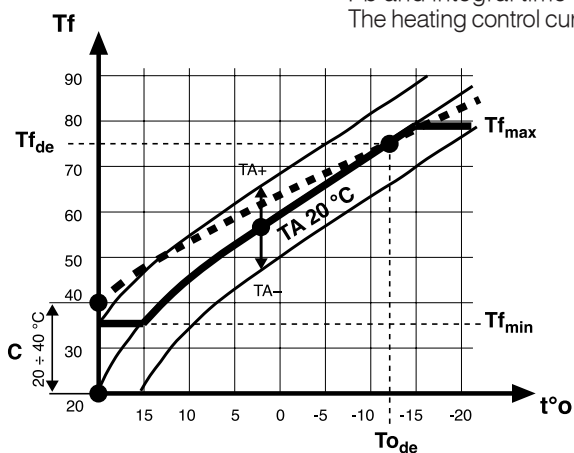

26.2

Design outside temp : - 5.0c

- design outside temperature : used for calculation of winter heat losses from building, depends on the climatic zone in which building is situated.

26.3

Design flow temp : 70.0c

- design flow temperature : used for determining thermal requirements of heating zone (eg: radiators = 70 °C ; fan coils = 80 °C ; panels = 40 °C).

- heating curve origin : winter flow temperature with outside temperature of 20 °C

The flow temperature required by controller depends also on value of ambient temperature required by operating mode: Normal , Setback , Frostprot (parallel ± adjustment of curve).

14.3 Origin of heating curve

26.4

**CurveOrigin TO20
Flow T : 20.0c**

The conventional point of origin of the heating curve (+ 20 °C flow at + 20 °C at + 20 °C outside temp.) can be adjusted by an increase in the flow temperature (Max. + 20 °C). The adjustment may be necessary to avoid possible imbalances in the output of the heat emitters with high outside temperatures (intermediate seasons).

14.4 Operating temperatures

XTE 600 permits configuring, with different desired temperature values, the various operating modes available, in particular :

23.1-23.5

**Desired temp
NORMAL 1 20.0c**

- 5 NORMAL =operation with compensated control to provide comfortable ambient temperatures (daytime or when building occupied)

23.6-23.7

**Desired temp
SETBACK 1 16.0c**

- 2 SETBACK = operation with compensated control to provide economical ambient temperatures (at night or when building unoccupied)

23.8

**Desired temp
FROSTPROT 6.0c**

- FROSTPROT=operation with control providing safety temperature (holidays or when building unoccupied)

23.9-23.10

**Desired temp
FLOW 1 30.0c**

- 2 FLOW = operation with control providing flow temperature at constant value (heating curve not taken into consideration)

- OFF = valve closed and pump idle

14.5 Minimum and maximum flow temperature limits

When the desired flow temperature reaches one of its limit values it is kept constant at that value.
 eg : - minimum limit to avoid circulation of cold air in fan coils
 - maximum limit to avoid dangerous overtemperatures in panels
 Warning : The maximum limit temperature does not substitute the requirements of the safety regulations in force.

26.5

Flow T limits
Min: 1c Max: 99c

14.6 Actuator run time

Choice of type of control for heating zone :

- Control : VALVE = control valve by three-wire actuator.
 Time : sec = time taken for a complete run (open/close) of valve actuator **necessary** for correct operation of controller.

or:

- Control : ON - OFF = ON-OFF = On-Off control in two stages.
 Different : c = On-Off temperature differential for each stage.

In this condition the Flow set-point received via C-Ring, even if Primary, is not taken into account by XTE 600"

26.6

Control : VALVE
Time : 630sec

14.7 Minimum start and stop times

26.7

Minimum start time : 60sec

26.8

Minimum stop time : 60sec

Appear only if in 23.6 appears: **Control : ON-OFF**
Different : 10.0c

- Minimum start time : 60 sec = minimum duration On control ;
- Minimum stop time : 60 sec = minimum duration Off control.

14.8 Ambient authority

When ambient sensor B3 is connected, the controller is able to adjust the desired flow temperature in accordance with the ambient authority set.
 When sensor B3 is not connected, the adjustment is made only in the Setback / Frostprot modes using the value of the ambient temperature calculated in relation to the time constant.

26.9

Ambient Authority
POSITIVE: + ----c

26.10

Ambient Authority
NEGATIVE: - ----c

- POSITIVE: **increase** of flow temperature for each °C difference between measured room temperature and the desired room temperature, when the measured room temperature is **below** the desired room temperature.
- NEGATIVE: **reduction** of the flow temperature for each °C difference between the measured room temperature and the desired room temperature, when the measured room temperature is **higher** than the desired room temperature.

14.9 Eco Off

Permits excluding heating when weather conditions do not require it :

- NO = disabled
- YES = enabled.

Functions only in Normal /Setback modes for :

$T_{fcal} - T_{aa} \leq 2^{\circ}C = \text{Eco Off : On}$
 $T_{fcal} - T_{aa} \geq 4^{\circ}C = \text{Eco Off : Off}$

where: T_{fcal} = calculated flow temperature
 T_{aa} = actual or calculated ambient temperature

23.16

Eco Off
NO

14.10 Operating programmes

Choice of operating programme for heating zone according to requirements :
 - 24HOUR 1...25; - 7DAY 1 - 2, - NORMAL 1...5; - SETBACK 1 - 2; FROSTPROT;
 - FLOW 1 - 2; OFF

22.2

Htg: -----
24HOUR 1

In place of programme the following may appear :

- SUMMER = controller is in summer period;
- HOLIDAY = controller is in holiday period;
- SPECIAL = controller is in special period;
- REMOTE EXTENSION = "Remote Extension" period has been activated (contact c1 and / or c2 closed). To cancel this function, on first page press <- and -> keys at same time;
- REMOTE NORMAL = external remote control "R" is in "Normal" position;
- REMOTE SETBACK = external remote control "R" is in "Setback" position;
- REMOTE FROSTPROT = external remote control "R" is in "Frostprot" position;
- REMOTE OFF = external remote control "R" is in "Off" position;
- REMOTE+2c = external remote control "R" is in "TAd + 2°C" position.

14.11 Operating mode and adjustment of temperature

22.3

Mode : NORMAL
Td20.0c Var+0.0c

The current modes depend on the programmes set in and can be seen on the two pages of the display :

22.2

Htg :
24HOUR 1

- NORMAL Td --.- c
- SETBACK Td --.- c
- FLOW Td --.- c
- FROSTPROT Td --.- c
- BOOSTING
- OPTIMSTOP
- OFF
- ECO OFF

In NORMAL / SETBACK operating modes it is possible to adjust the value of the desired temperature :

- Var + = variation of $\pm 3^{\circ}\text{C}$

14.12 Modifying programmes by remote control

27.4

Input B6
REMOTE CONTROL

The remote control "R"(CDB300) can be used as an alternative to flue gases sensor B6 (see 17. "Complementary functions"). Permits modifying current programme :

- OFF = plant excluded
- FROSTPROT = continuous operation at desired Frostprot ambient temp.
- NORMAL = continuous operation at desired Normal 1 ambient temp.
- SETBACK = continuous operation at desired Setback 1 ambient temperature
- TAd +2c = increase of 2 °C in temp. desired by current mode.
- AUTOMATIC = operation with programme chosen for controller

14.13 Control heating zone pump

26.18

Heating pump: AUT
Delay Off : 30min

The heating zone pump can be controlled in two ways :

- MAN = Pump in continuous operation
- AUT = Pump controlled according to current modes :
 - Off : pump always Off
 - Eco Off : pump always Off
 - Remote extension : pump always On
 - Normal : pump always On
 - Setback, Frostprot & Optimstop:
 - pump Off after switching off delay.
 - pump On when actual or calculated ambient temperature is below calculated flow temperature
 - Boosting : pump always On
 - Flow : pump always On

- Delay Off : 30 min = delay time in switching off to dissipate heat accumulated in plant (minimum two minutes).

14.14 Metering degree-days

25.7

Degree - Days
20 : xxxx Amb: xxxx

XTE 600 meters degree-days in two ways :

- 20 = metering of degree-days with reference to conventional ambient temperature of 20 °C
- Amb = metering of degree-days with reference to actual ambient temperature (with sensor B3) or to that calculated (without B3)

15. OPTIMISATION

Start and stop of plant at variable times so as to obtain desired ambient temperatures in coincidence with times of start and end of occupancy. Useful for buildings with discontinuous occupancy such as schools and commercial and public offices.

The method of establishing the time of optimised start depends on the presence or not of the ambient sensor.

15.1 Optimisation with ambient sensor

The start time is established by the meeting point of the descending curve of the actual ambient temperature with plant OFF or in SETBACK/FROSTPROT mode, and the required temp. curve defined by the parameter "Start inertia".

With "Start inertia " on AUTOMATIC : if the desired ambient temperature is reached too soon or too late in respect of the time desired, the controller adjusts the start time of the following day by ± 15 minutes until the optimum time is obtained.

15.2 Optimisation without ambient sensor

With "Start inertia " set on MANUAL (not permitted on automatic) the start time is established by the controller on the basis of the "Cooling time constant " (26.14).

15.3 Enabling of the function

23.17

OptimumStart : NO
Optimum stop : NO

- Optimum start = automatic adjustment of start time of plant after night stop / setback or after holidays.
 - NO = optimum start function disabled
 - YES = optimum start function enabled
- Optimum stop = stop before end of NORMAL (day) mode.
 - NO = optimum stop function disabled
 - YES = optimum stop function enabled
- The functions are not enabled in FLOW 1 and 2 modes and are operative only at first and last event of programme.

15.4 Start inertia

26.11

Start inertia
MANUAL 1.00h/c

Time necessary (hours / °C) for plant to increase ambient temperature by 1 °C.

- MANUAL = value can be adjusted only manually
- AUTOMATIC = (only with ambient sensor) automatic daily adjustment of ± 15 minutes.

15.5 Duration of normal optimisation

26.12

Opt start normal
Max durat : 2.00h

Maximum time in advance for first startup of plant when controller uses one of 7-day and / or 24-hour programmes available; in practice, start after being switched off for a night.

15.6 Duration of optimisation after holidays

26.13

OptStart holiday
Max durat : 10.00h

Maximum time in advance for first startup of plant after a holiday period.

15.7 Boosting

26.14

Optimum start
Boosting : 3.0c

Increase in desired ambient temperature, and consequently in flow temperature, during optimum start period, so as to reduce time for heating zone to reach required temperature. With ambient sensor, if desired ambient temperature is reached before desired time, controller switches to compensated control according to programme.

15.8 Time constant

26.15

Cooling Time
Constant : 48 hrs

Time taken by ambient temperature, with heating zone excluded, to decrease by 2/3 its initial value. It is used by controller to calculate ambient temperature (in SETBACK / FROSTPROT modes) when plant is without ambient sensor.

15.9 Reduction of temperature for optimum stop

26.16

Optimum stop
DecreaseTA : 0.5c

Maximum decrease in ambient temperature permitted at time of end of occupancy in respect of desired ambient temperature.

15.10 Maximum optimum stop

26.17

Optimum stop
Max durat : 1.00h

Maximum time in advance permitted for stopping plant in respect of time of end of occupancy.

The time is calculated in relation to temperature decrease set in ^{25.15} **Optimum stop** **DecreaseTA 0.5c** with

ambient sensor and to "Cooling time constant" without ambient sensor. With ambient sensor : if ambient temperature decreases, by reduction value set, before time of end occupancy, the controller returns to operating according to programme.

16. CONTROL DHW

27.5

DHW sensor B5 :
USED

When sensor B5 is connected and "Config XTE 600" is enabled, the controller controls DHW pump M2 according to operating programme selected and desired temperature set.

16.1 Desired temperature

23.11

Desired temp
DHW 50.0c

Value of temperature desired for DHW storage. When DHW control switches on the M2 pump the controller sends in C-Ring the desired DHW temperature increased by the value set in

26.22

IncreasTCRing on
Des DHW T : 5.0c

16.2 Differential and antibacteria

26.30

DHW diff : 3.0c
Antibacteria : NO

- DHW Diff = temperature difference for control of DHW pump M2.
- Antibacteria = increase in DHW temperature to 70°C for 90 minutes every Wednesday at 02:00 so as to avoid formation of bacteria inside storage tank.
 - NO = function not enabled
 - YES = function enabled

16.3 Operating programmes

23.12

DHW summer : YES
ALWAYS ON

- Operation of DHW calorifier during summer period :
 - YES = DHW calorifier in operation
 - NO = DHW calorifier Off
- Choice of operating programme :
 - 24HOUR 1...25; - 7DAY 1 - 2, - FOLLOWS HEATING;
 - ALWAYS ON; - ALWAYS OFF;

NB: if "FOLLOWS HEATING" is entered and "DHW summer : YES", DHW in summer period is, however, Off.

16.4 Operating modes

DHW control uses one of the programmes available on controller. However, when preparing a 24-hour programme specially for DHW, note that the available modes have the following meanings :

- NORMAL 1...5; SETBACK 1 - 2 = ON (On) = Desired DHW T
- FLOW 1 - 2; FROSTPROT; OFF =OFF (Off) = Desired DHW T

23.11
Desired temp
DHW 50.0c

23.8
Desired temp
FROSTPROT 6.0c

The same applies even when the DHW programme is "FOLLOWS HEATING".

16.5 Delay switching off pump

26.19

DHW pump
Delay Off : NO

Delay in switching off DHW pump when desired DHW temperature reached :

- NO = no delay
- YES = delay of 5 minutes (fixed) in switching off.

16.6 DHW priority

26.21

DHW priority
NO

DHW priority over heating

- NO = function excluded
- YES = when DHW temperature, measured by sensor B5, falls below desired value the controller, if pump is switched on, closes heating valve by modulating action.

16.7 Timed control

27.4

DHW sensor B5
NOT USED

When you want to use the auxiliary output (M2) to control times it is essential to disable in "CONFIG XTE 600" the sensor B5: NOT USED.

Factory setting for B5 sensor is USED and associated with the control of calorifier (M2).

Warning: when the controller is used for the control of a burner, the switching on of the auxiliary output (M2) does not bring about the switching on of the boiler (see example of site 10.2, page 4).

17. PROGRAMMES & PERIODS WITH DATES

All programmes with timed events are available both for compensated control and for the control of DHW.

The periods with dates refer to compensated control and are followed by DHW control only if this is programmed as "FOLLOWS HEATING".

17.1 24-hour programmes

24.1

How many 24hour
programmes? 1

Enter number of 24-hour programmes you wish to use (from 1 to 25).

In each 24-hour programme (P1 ... P25) you can set a maximum of 6 event start times (Event 1 ... Event 6) assigning to each one of following modes :

24.2

P1 Event 1 06.00
NORMAL 3 21.0c

- NORMAL 1...5 = compensated control with NORMAL ambient temperature
- SETBACK 1 - 2 = compensated control with SETBACK ambient temperature
- FLOW 1 - 2 = control with fixed FLOW temperature
- FROSTPROT = compensated control with FROSTPROT ambient temperature
- OFF = plant Off, valve closed and pump idle

24.7

P1 Event 6 22.00
SETBACK 1 16.0c

The event start times must be entered in increasing order.

Events not used must be excluded by pressing + and - keys at the same time.

Unused times must not be left between programmed events.

17.2 7-day programmes

24.8

How many 7day
programmes ? 0

Enter number of programmes you wish to use (max 2)

In each 7-day programme you can assign to each day of the week one of following programmes :

24.9

7day 1 MONDAY
24HOUR 1

- 24HOUR 1 ...25;
- NORMAL 1...5;
- SETBACK 1 - 2;
- FLOW 1 - 2;
- FROSTPROT ;
- OFF.

24.15

7day 1 SUNDAY
24HOUR 1

17.3 Holiday periods

24.16

How many holiday periods ? 0

These establish an operating programme, the same for all holiday periods, which overrides the programme in use. At the end of each holiday period the controller returns to normal operation.

To reduce the number of display pages dedicated to entering the dates, enter number of holiday periods or of bank holidays you wish to use (max. 25).

If left at 0 the programming pages do not appear.

Choose programme to be used during all the holiday periods :

24.17

Holiday program FROSTPROT 6.0c

- 7DAY 1 - 2; - 24HOUR 1 ... 25; - NORMAL 1 ... 5; - SETBACK 1 - 2;
- FLOW 1 - 2; - FROSTPROT ; - OFF.

Enter the dates for each single holiday period :

24.18

Hol 01 start NO
Fr - . . . - to - . . . -

- Hol 01 = choice of periods made available by
- Htg : - NO = unused holiday period
- 00 = start period at 00.00 hours
- 12 = start period at 12.00 hours
- Fr - . . . - to - . . . - = day and month of start and end of holiday period

23.16

How many holiday periods ? 0

For a single day of holiday enter the same date for start and end.
To cancel holiday period keep + and - keys pressed at the same time.

17.4 Special period

22.5

Special program 24HOUR 1

Period in which compensated control is obliged to use an operating programme to meet particular requirements and which overrides temporarily the one in use :

- 7DAY 1 - 2; - 24HOUR 1 ... 25; - NORMAL 1 ... 5; - SETBACK 1 - 2;
- FLOW 1 - 2; - FROSTPROT ; - OFF.

22.6

Special period
Fr - . . . - to - . . . -

- Fr - . . . - to - . . . - = day and month of start and end of holiday period

17.5 Remote extension period

23.13

Remote Ext 21.0c for hours 3

The remote extension period overrides all programmes and modes in use, obliging the heating zone to operate for the time and at the temperature set . To activate the extension function, close switch **c1** for at least five seconds. At the end of the duration set the controller will resume its automatic operation.

- Extension 21.0c = setting of ambient temperature required during extension period.
- for hours : 3 = setting duration of extension period.

To interrupt extension period before expiry of time set press ← and → keys together.

17.6 Heating season

24.19

Heating season
Fr - . . . - to - . . . -

Establishes the winter heating season.
Enter day and month of start and end of heating season.

Applies also to DHW if "Summer DHW : NO" entered in

23.12

DHW summer: YES ALWAYS ON

To cancel press + and - keys together.

17.7 BST period

24.20

BST period AUT
Fr 29.03 to 26.10

The controller can automatically change the current time of day at the beginning and end of the daylight saving period.

- AUT = The change from BST to GMT and *viceversa* is automatic.
 - MAN = you can set date different from that of European Community
- To cancel the period, press + and - keys simultaneously

18. COMPLEMENTARY FUNCTIONS

18.1 Anticondensing function

23.14

Priority
Anticondens : NO

Choice of enabling or not anticondensing function :
 - NO = function excluded
 - YES = when return to boiler temperature (measured by sensor B4) falls below desired anticondensing temperature the controller closes heating zone valve with modulating action.

23.14

T. Anticondens
Desired : 50.0c

• Desired : - . - c = value of anticondensing temperature. Appears if sensor B3 is connected.

18.2 Input B6 and B7

27.4

Input B6
FLUGAS + ALARM

Configuration of sensor B6 input :
 - FLUGAS + ALARM = if Pt 1000 flue gases sensor and/or an alarm contact connected.
 - REMOTE CONTROL = if remote control CDB300 connected.

27.6

Input B7
NOT USED

Configuration of sensor B7 input :
 - USED = if a 4...20 mA sensor with accessory ASA 420 is connected
 - NOT USED = the input is not used

18.3 Summer plant exercise

23.18

Summer plant
exercise: NO

This function, which is applicable to both heating and DHW, prevents lockouts of valves and pumps when plant is not used for prolonged periods.

- NO = function excluded
 - YES = every Sunday at 11.00 the valves are opened for 15 minutes and at 12.00 the pumps are run for 5 minutes.

18.4 Access keynumber

27.8

Choice keynumber
- - - -

Choice and enabling of access keynumber which prevents use of + and - keys for modification of data. Enter the number (1900 ... 1999) using + and - keys.
 To cancel keynumber, press + and - at the same time until dashes reappear.

Access keynumber
- - - -

When keynumber is enabled, if + or - keys are pressed on the display appears the request to enter keynumber. Only after having entered the correct keynumber can + and - keys be used.
 If for 15 minutes no key is pressed the keynumber is automatically re-enabled.

18.5 Denomination of heating zone and auxiliary circuit (M2)

27.9

Name Heating Zone
- - - - -

Entering name of heating zone.
 Each dash can be replaced, using + and - keys, by a letter of the alphabet (A ...Z) or by a number (0 ... 9). The → key serves to position the cursor.

27.13

Name Auxiliary
Circuit: DHW

Entering name of auxiliary circuit.
 Factory setting: DHW.

18.6 Display of measurements

The controller displays all the values measured by the sensors and the data necessary to monitor the operational status of the plant :

25.1

Des Amb T : 21.0c
Act Amb T : 21.0c

• **ambient temperature** desired by current mode and actual measured by sensor B3.
 If sensors are not connected, in place of Act Amb T appears Cal Amb T .

25.2

Des Flow T : 65.0c
Act Flow T : 64.0c

• **flow temperature** desired by current mode and actual measured by sensor B1.

25.3

Outside temp
Actual : - 2.0c

• **outside temperature** actual . If sensor B2 is not connected to controller, in place of "actual" appears "C-Ring" and value is that coming via C-Ring.

25.4

Des AnticT : 50.0c
Act AnticT : 58.0c

• **anticondensing temperature** desired by current mode and actual measured by sensor B4.
 If sensor B4 is not connected there appears Act AnticT: - . - .

25.5

Des DHW T : 50.0c
Act DHW T : 52.0c

• **DHW temperature** desired by current mode and actual measured by sensor B5.
 If sensor B5 is not used ^{27.4} the screen shot not appear.

DHW sensor B5:
NOT USED

25.6

Flugas Max 185c
B7 : 2.0mA

• **temperature max. flue gases and active sensor**
 - if input B6 is configured as "REMOTE CONTROL" there will appear "B6: REMOTE" instead of Flugas Max.

18.7 Data recording

The controller, at each change of mode and every hour, records a series of data indicating the operational status of the heating zone/DHW circuit controlled :

- Actual time of day, day and type of recording (change of mode or expiry of hour period) ; current mode, actual outside temp., compensated flow temp., desired and actual flow temp., desired and actual ambient temp., anticondensing temp.
- relay outputs status

The controller can memorise 28 complete recordings and the last recording brings about the cancellation of the oldest one.

If the display does not show the first page, the controller makes the recording at the expiry of the hour period, but not that at change of mode because it presumes changes to the setting data are in progress.

The recordings can be displayed only by the telemanagement PC.

19. ALARMS

The alarms processed by the controller are of three types :

- alarms for the faulty operation of the controller and of the heating zone/DHW circuit controlled;
- alarms for short or open circuits sensors connected
- alarms from external contacts

The alarm state is indicated by the LEDs on the controller facia and by the word "ALARM" appearing on the display and is identified, on the configuration page, by the letter "A" alternating with the number of the alarm concerned.

With C-Bus setup the alarms can be sent to a local PC and/or to the telemanagement central PC.

19.1 Functional alarms

The functional alarms are triggered in the presence of prolonged differences between actual and desired values.

With the exception of the real time clock alarm (8) they do not affect the correct operation of the controller

Factory setting : all disabled except for real time clock alarm (8).

Using + and - keys enable the alarms of interest by replacing dashes with numbers.

When number blinks = alarm triggered.

The limit values and the delay times for sending alarms can only be modified by PC.

26.4

Functional Alarms
- - - - 8

Type of alarm and causes :

- 1** = temperature difference heating flow 1 (B1)
 - enabled with pump M1 in operation
 - triggered when actual temperature below that desired.
- 3** = temperature difference ambient (B3)
 - enabled with NORMAL modes and with outside temperature below desired ambient temperature.
 - triggered when actual temperature below or above that desired.
- 5** = temperature difference DHW (B5) 27.4
 - enabled when pump M2 in operation, if DHW sensor B5 : USED
 - triggered when actual temperature below that desired
- 6** = overtemperature flue gases (B6)
 - enabled if input B6 is configured as "FLUGAS + ALARM"
 - triggered if actual temperature above maximum limit.
- 7** = active 4 ... 20 mA sensor (B7)
 - triggered if actual value 4 ... 20 mA exceeds for at least one minute minimum or maximum thresholds set.
- 8** = internal real time clock : cannot be disabled
 - triggered when clock assumes meaningless values.

19.2 Sensor alarms

The sensor alarms are triggered in the event of **open** or **short** sensor circuits.

Using + and - keys disable alarms not of interest by substituting dashes for numbers.

26.5

Detector alarms
1 2 3 4 5 6 8

Type of alarm and effect at moment of triggering :

- 1** = flow 1 sensor (B1) : valve Y1 stops in position it happens to be in and pump M1 maintains its status (idle or in operation).
- 2** = outside sensor (B2) :valve stops in position it happens to be in and pump maintains its status (idle or in operation); in C-Ring last value measured continues to be transmitted.
- 3** = ambient sensor (B3) : actual ambient temp. is calculated by controller.
- 4** = anticondensing sensor (B4) : anticondensing function disabled.
- 5** = DHW sensor (B5) : output M2 idle.
- 6** = flugas sensor (B6) : alarm.
- 8** = C-Ring : open electric circuit or fault in one of controllers in ring.

The triggering of the alarms is delayed by one minute only provided the relative alarms are enabled. Factory setting : all enabled

19.3 Alarms or status from external contacts (k)

26.6

K a l a r m s
- - - - -

Alarms triggered by closure of voltage-free contacts **k1 ... k4** regarding plant components (pumps, burners, etc).
Using + and – keys enable alarms of interest by replacing dashes with numbers.

The presence of the alarm is indicated after about 60 seconds.
Factory setting : all disabled.

When number blinks = alarm triggered.
If not used as alarms they can be used as status indicators .

20. TESTING AFTER COMMISSIONING

Testing to be carried out when installation has been completed and electric wiring and configuration carried out and tested.

20.1 Testing C-Ring

M8.5

CRing connection
PRIMARY
SECONDARY

The C-Ring testing page appears only if it is configured in

27.1

CRing : ??

Ensure that all the other controllers connected in C-Ring are:

- correctly powered at mains voltage (230 VAC, or 240 V AC for UK market).
- Slave controllers or configured as SECONDARY in **CRing connection: SECONDARY**
- selected on testing page **CRing:??**

The PRIMARY controller sends via C-Ring a signal every 5 seconds. On all the displays appears “?”. If the connection is satisfactory the word “YES” replaces “?” on all the displays. If on one or more displays “YES” does not appear, this means that there is a break in the connection between the last controller with “YES” and the first with “?”.

Examples of testing a C-Ring with four controllers:

- Cont. 1 "OK" – Cont.2 "OK" – Cont.3 "OK" – Cont.4 "OK" : C-Ring OK
- Cont. 1 "??" – Cont.2 "OK" – Cont.3 "OK" – Cont.4 "OK" : Fault between 4 and 1
- Cont. 1 "??" – Cont.2 "OK" – Cont.3 "??" – Cont.4 "??" : Fault between 2 and 3
- Cont. 1 "??" – Cont.2 "??" – Cont.3 "??" – Cont.4 "??" : Fault between 1 and 2

20.2 Testing outputs

27.2

Output : VALVE
Status : IDLE

With + and – keys choose :

- output to be tested :
 - VALVE;
 - PUMP;
 - DHW;
- status :
 - with VALVE : IDLE ; CLOSED ; OPEN
 - with PUMP and DHW : ON or OFF

Check the result

21. SEQUENCE OF DISPLAY PAGES (the data and functions are those in memory at time of delivery)

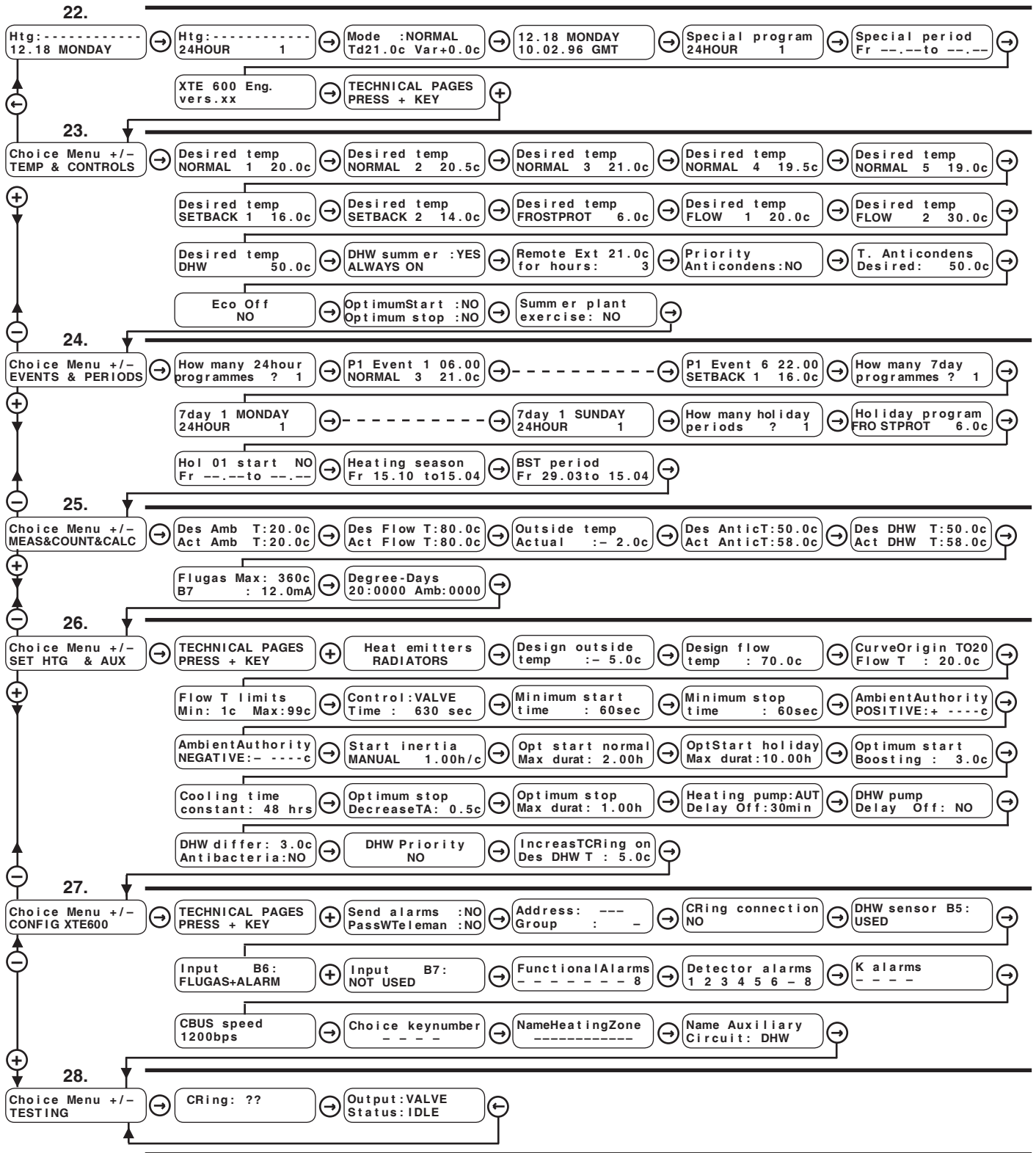

← → Keys for scrolling pages on the display and positioning cursor █ on the data which can be changed. The data which can be changed, in the following descriptive list of display pages, are highlighted thus Htg:----- 12.18 MONDAY. By pressing these keys at the same time (or in any event after 15 minutes) the first page appears on the display.

⊖ ⊕ Keys for : - changing the values highlighted by the cursor █
 - viewing the configuration options of a function, for example : Type of plant
FAN-COIL or Heat emitters
PANELS
 - passing directly from one menu (series of pages) to another.

22. NORMAL USE				
Ref.	Display	Description	Notes	Sect
22.1	Htg: ----- 12.18 MONDAY	Name heating zone Current time and day	Set in 27.8 Set in 22.4	
22.2	Htg: ----- 24HOUR 1	Choice current programme : 7DAY 1-2 ; 24HOUR 1...25; NORMAL 1...5; SETBACK 1-2; FLOW 1-2; FROSTPROT; OFF.	Instead of programme may appear : SUMMER; HOLIDAY; SPECIAL; REMOTE EXTENSION; REMOTE NORMAL1; REMOTE SETBACK 1; REMOTE FROSTPROT; REMOTE OFF; REMOTE+2C.	14.10
22.3	Mode : NORMAL Td21.0c Var+0.0c	Current mode. Td : Mode desired temperature Var : Variation of desired temp. (max ± 3 °C)	Current modes : NORMAL ; SETBACK ; FLOW; FROSTPROT; OFF; ECO OFF; BOOSTING;OPTIMSTOP;REMOTE EXTENSION.	14.11
22.4	12.18 MONDAY 10.02.96 GMT	Setting : Time, day of week and date. Current time period : BSTor GMT	Dates BST period set in 24.20 .	
22.5	Special program 24HOUR 1	Choice programme special period: 7DAY 1-2; 24HOUR 1...25; NORMAL 1...5; SETBACK 1-2; FLOW 1-2; FROSTPROT; OFF.		17.4
22.6	Special period Fr --- to ---	Dates of start and end of special period	Press + and – together to cancel.	17.4
22.7	XTE 600 C1 Eng. Vers.xx	Identifying data of controller		
23. TEMP & CONTROLS				
Ref.	Display	Description	Notes	Sect.
23.1 23.5	Desired temp NORMAL 1 20.0c	Value of desired ambient temp. NORMAL 1 ... 5 to be used in 24-hour programmes in 24.2 .		14.4
23.6 23.7	Desired temp SETBACK 1 16.0c	Value of desired ambient temp. SETBACK 1-2 to be used in 24-hour programmes in 24.2 .		14.4
23.8	Desired temp FROSTPROT 6.0c	Value of desired ambient temp. FROSTPROT to be used in 24-hour programmes in 24.2 .		14.4
23.9 23.10	Desired temp FLOW 1 20.0c	Value of desired temp. FLOW 1-2 to be used in 24-hour programmes in 24.2 .		14.4
23.11	Desired temp DHW 50.0c	Value of desired DHW temperature.		16.1
23.12	DHW summer : YES ALWAYS ON	Use of DHW during summer period. Choice of programme to be used : 7DAY 1-2; 24HOUR 1...7; FOLLOWS HEATING; ALWAYS ON; ALWAYS OFF.	SUMMER = period not included in heating season set in 24.19	16.3
23.13	Remote Ext 21.0c for hours : 3	Desired temp. during EXTENSION period. Duration of EXTENSION period.	To activate EXTENSION period keep closed switch c1 for at least 5 seconds (see wiring diagram). To disactivate EXTENSION period keep pressed to- gether ← and → keys from first page display.	17.5
23.14	Priority Anticondens : NO	Enabling of anticondensing function : NO ; YES.		18.1
23.15	T.Anticonden : NO Desired : 50.0c	Setting value anticondensing temperature.	NO: function excluded YES: When return-to-boiler temp. (B4) < desired an- ticondensing temp. controller closes heating valve with modulating control action.	18.1
23.16	Eco Off NO	Eco Off function : NO; YES.	In Normal or Setback modes with : • Calculated flow temp. - measured or calculated ambient temp. ≤ 2 °C = Eco Off : On, valve closed & heating pump Off and if scheduled boiler Off. • Tfd - Ta meas. or calc. ≥ 4 °C = Eco Off : Off	14.9
23.17	OptimumStart : NO Optimum stop : NO	Functions of Optimum Start and Optimum Stop : NO ; YES.		15.3
23.18	Summer plant exercise : NO	Summer plant exercise function : NO ; YES.	During summer period, to prevent lockouts, control- ler switches on periodically valves & pumps.	18.3
24. EVENTS & PERIODS				
Ref.	Display	Description	Notes	Sect.
24.1	How many 24hour programmes ? 1	Choice of number of 24-hour programmes to be used (1...25).	Avoids scrolling unnecessary display pages	17.1
24.2 ↓ ↓ 24.7	P1 Event 1 6.00 NORMAL 3 21.0c P1 Event 6 22.00 SETBACK 1 16.0c	Number of programme, number of event & time of start event in programme. Choice type of mode to assign to event : NORMAL 1...5; SETBACK 1- 2; FROSTPROT; FLOW 1 - 2; OFF. Further groups of 6 pages according choice in 24.1	Max. 6 periods. To eliminate unused period press + and – together : dashes appear. The events must be in increasing order. Do not leave dashes between programmed events. Modes set are winter ones.	17.1

24. EVENTS & PERIODS				
Ref.	Display	Description	Notes	Sept.
24.8	How many 7day programmes ? 0	Choice number of 7-day programmes to be used (1-2).	Avoids scrolling unnecessary display pages	17.2
24.9	7day 1 MONDAY 24HOUR 1	Choice of programme for each day of week : 24HOUR1...25 ; NORMAL 1...5; SETBACK 1 - 2; FROSTPROT ; FLOW1 - 2; OFF.		17.2
↓				
24.15	7day 1 SUNDAY 24HOUR 1			
24.16	How many holiday periods ? 0	Choice of number of holiday periods to be used (0...25)	Avoids scrolling unnecessary display pages	17.3
24.17	Holiday program FROSTPROT 6.0c	Choice of programme for all holiday periods : 7DAY1-2; 24HOUR1...25; NORMAL 1 ... 5; SETBACK1 ... 2; FROSTPROT; FLOW 1 - 2; OFF.	Appears only if in 24.16 number entered is greater than 0	17.3
24.18	Hol 01 start NO Fr --- -- to --- --	NO = period not used; 00 = start 00 hours; 12 = start 12 hours Dates of start and end of holiday period.	Appears only if in 24.16 number entered is greater than 0	17.3
24.19	Heating season Fr:15.10to:15.04	Dates of start and end of heating season.		17.6
24.20	BST period AUT Fr:29.03to:26.10	Dates of start and end of BST period.		17.7

25. MEAS&COUNT&CALC				
Ref.	Display	Description	Notes	Sept.
25.1	Des Amb T:20.0c Act Amb T:20.5c	Ambient temperature desired by current mode. Temperature measured by ambient sensor B3.		18.6
25.2	Des Flow T:80.0c Act Flow T:80.0c	Flow temp. desired by current mode Temp. measured by flow sensor B1		18.6
25.3	Outside temp Actual :- 2.0c	Actual outside temp. measured by B2 or coming via C- Ring .	If outside sensor B2 not connected & value comes via C- Ring, Actual is replaced by C- Ring .	18.6
25.4	Des AnticT:50.0c Act AnticT:58.0c	Desired anticondensing temp. Temp. measured by anticondensing sensor B4.		18.6
25.5	Des DHW T:50.0c Act DHW T:52.0c	Desired DHW temp. in On mode Value measured by DHW sensor B7.	Appears only if in 27.4 B5 is USED.	18.6
25.6	Flugas Max 185c B7 : 2.0mA	Maximum temp. measured by B6. Value measured by active sensor B7.	If in 27.5 B6 is REMOTE CONTROL there will appear : B6 REMOTE Appears only if in 27.6 B7 is USED.	18.6
25.7	Degree-Days 20:0000 Amb:0000	20: referred to fixed ambient temp. of 20 °C Amb: referred to actual or calculated ambient temp.	Press + and - for 5 seconds to cancel value.	14.14

26. SET HEATING & AUX				
Ref.	Display	Description	Notes	Sept.
26.1	Heat emitters RADIATORS	Choice type heat emitters : RADIATORS ; PANELS ; FAN COILS		14.1
26.2	Design outside temp :- 5.0c	Value design outside temp. for compensated control		14.2
26.3	Design flow temp : 70.0c	Value design flow temp. for compensated control		14.2
26.4	CurveOrigin TO20 Flow T : 20.0c	Correction heating curve origin		14.3
26.5	Flow T limits Min:1c Max:99c	Minimum and maximum limits flow temperature		14.5
26.6	Control: VALVE Time: 630sec	Type of control : VALVE; ON-OFF. • Speed of actuator if VALVE or • On-Off differential if ON-OFF.		14.6
26.7	Minimum start time : 60sec	Minimum duration start period of each stage.	Appears only if in 26.6 ON-OFF is entered.	14.7
26.8	Minimum stop time : 60sec	Minimum duration stop period of each stage.	Appears only if in 26.6 ON-OFF is entered.	14.7

26. SET HEATING & AUX				
Ref.	Display	Description	Notes	Sect.
26.9	Ambient Authority POSITIVE: + ----c	Ambient authority. Variation in + °C flow temp. with - 1 °C difference in ambient temp.		14.8
26.10	Ambient Authority NEGATIVE: - ----c	Ambient authority. Variation in - °C flow temp. with + 1 °C difference in ambient temp.		14.8
26.11	Start inertia MANUAL 1.00h/c	Optimising inertia at start	MANUAL= correction of value manually AUTOMAT = correction of value automatically	15.4
26.12	Opt start normal Max durat: 2.00h	Maximum duration period optimum start after period of 24-hour or 7-day operation		15.5
26.13	OptStart holiday Max durat: 10.00h	Maximum duration period optimum start after a holiday period		15.6
26.14	Optimum start Boosting : 3.0c	Increase in desired ambient temp. during optimum start period		15.7
26.15	Cooling Time Constant: 48 ore	Used when ambient sensor B3 not installed to calculate decrease in ambient temp.		15.8
26.16	Optimum stop DecreaseTA: 0.5c	Value of reduction in desired ambient temp. at last event end occupancy		15.9
26.17	Optimum stop Max durat: 1.00h	Maximum duration period optimum stop		15.10
26.18	Heating pump:AUT Delay Off: 30min	Control plant pump: MAN; AUT. Delay switching off pump	MAN: always On AUT: On with event times of current programme Appears if in 27.4 is USED	14.13
26.19	DHW pump Delay Off: NO	Delay switching off pump.	NO: without delay; YES: 5 minutes delay. Appears if in 27.4 is USED	16.5
26.20	DHW differ: 3.0c Antibacteria: NO	Value of differential control pump. Enabling of antibacteria function: NO; YES.	NO: antibacteria function excluded YES: every Wednesday at 12 noon DHW temperature increased to 70 °C. Appears if in 27.4 is USED	16.2
26.21	DHW priority NO	Enabling of DHW priority function : YES; NO.	NO: function excluded YES: when M2 On, modulating closure valve when measured DHW temp. < desired temp. Appears if in 27.4 is USED	16.6
26.22	IncreasTCRing on Des DHW T : 5.0c	Increase in desired DHW temperature to obtain the temperature sent in C-Ring when in operation the DHW pump M2 (range: 0...50 C°, resolution 0.5 C°).	Appears if in 27.3 is not NO and if in 27.4 is USED.	16.6

27. CONFIG XTE 600				
Ref.	Display	Description	Notes	Sect.
27.1	Send alarms : NO PassWTeleman: NO	Enabling alarms to send to telemanagement PC Enabling telemanagement keynumber	Only if connected in C-Bus	11.5
27.2	Address : ---- Group : -	Telemanagement address of controller Group to which controller assigned	Only if connected in C-Bus	11.4
27.3	CRing connection NO	NO = not connected in C - Ring PRIMARY = connected as Primary SECONDARY = connected as Secondary		11.1
27.4	DHW sensor B5: USED	- USED : sensor connected - NOT USED : sensor not connected	With B5 sensor connected the M2 output is controlled by times and/or by temperature. With B5 sensor not connected the M2 output is controlled by times only.	18.2 14.12
27.5	Input B6 FLUGAS + ALARM	Configuration of input sensor B6 : FLUGAS+ALARM; REMOTE CONTROL.	FLUGAS+ALARM: flue gas sensor + alarm input REMOTE CONTROL: remote control R	18.2 14.12
27.6	Functional Alarms 1 3 5 6 7 8	Disabling functional alarms Factory setting : only 8 enabled (cannot be disabled)	1 : Alarm flow temp. B1. 3 : Alarm ambient temp. B3. 5 : Alarm DHW temp. B5. 6 : Alarm flugas temp. B6. 7 : Alarm active sensor B7. 8 : Alarm internal real time clock	19.1
27.7	Detector alarms 1 2 3 4 5 6 8	Enabling alarms sensor short or open circuits. Factory setting : all enabled.	1 : Flow sensor B1. 2 : Outside sensor B2. 3 : Ambient sensor B3. 4 : Anticondensing sensor B4. 5 : DHW sensor B5. 6 : Flugas sensor B6. 8 : C- Ring alarm	19.2

27. CONFIG XTE 600				
Rif.	Display	Descrizione	Note	Sect.
27.8	K a l a r m s - - - -	Enabling On-Off alarms. Factory setting : all disabled.		19.3
27.9	CBUS speed 1200 bps	The speed of the communication bus (C-Bus) can be chosen from: 1200, 2400, 4800, 9600 bouds.		
27.10	Choice keynumber - - - -	Choice keynumber for preventing use + and – keys. A number between : 1901 ... 1999	To eliminate keynumber press + and – together.	18.4
27.11	NameHeatingZone - - - - - - - -	Entering name heating zone + DHW	Use + and – to enter letters or numbers. Use ← and → to move cursor.	18.5
27.12	Name Auxiliary Circuit: Boiler	Entering name Auxiliary circuit. Factory setting : Boiler.	Use + and – to enter letters or numbers. Use ← and → to move cursor.	
27. TESTING				
Ref.	Display	Description	Notes	Sect.
28.1	CRing : ??	Page of testing C- Ring connections. ?? = C-Ring test in progress or test failed YES= test OK		20.1
28.2	Output : VALVE Status : IDLE	Choice outputs to be tested Choice status of output.	Choice output : VALVE ; PUMP ; DHW; Choice status: With VALVE : IDLE ; CLOSED; OPEN. With PUMP, DHW: ON; OFF.	20.2

Amendments to data sheet

Date	Revision No.	Page	Section	Details of amendments	Firmware version	Software version
13.12.05 LB		13 8	25. SET HTG & DHW 15.1 Desired DHW temperature	Added page Display 25.20 for setting increase desired DHW temp. to send to C-Ring DHW temperature increase in C-Ring		
28.12.05 LB		2	4. TECHNICAL DATA	Added item: "Increase C-Ring over desired DHW temperature"		
25.01.07 MM		12	14.6 Actuator run time.....	Added item about C-Ring		
29.07.09 VM	01	various	various	Change to version C1		
24.05.10 VM	02	9	16.2 Differential and antibacteria	Changed antibacteria function's time		≥ 0.99.2650
22.11.10 VM	03	3	9. Wiring	Wiring procedure modified		≥ 0.99.2650

**Head Office & Sales**

Via San G.B. De La Salle, 4/a Tel. +39 022722121
20132 - Milano Fax +39 022593645
Orders Fax +39 0227221239
Reg. Off. Central & Southern

Via S. Longanesi, 14 Tel. +39 065573330
00146 - Roma Fax +39 065566517

Shipping

Via Gen. Treboldi, 190/192 Tel. +39 0364773200
25048 - Edolo (BS) Tel. +39 0364773202

E-mail: info@coster.eu Web: www.coster.eu



D 33294