

ELECTRONIC MIXING UNITS FOR DWH

MAS... C2 Eng.



- Supplied with valve, actuator, controller & temperature detector
- Valve connections : DN 1/2"...2" female threaded
- Temperature control range : 30...70 °C
- Very stable temperatures even with low flows
- Power supply: 230 V~ ; Consumption: 6...9 VA; Protection: IP 55

1. APPLICATION

MAS electronic mixers maintain water temperature at the desired level by mixing directly hot water from a storage tank or a heat generator and cold water from the water mains, Accordingly, they are useful for the efficient and economic management of DHW distribution systems.

2. OPERATION

MAS mixers are very compact and comprise two parts:

- electronic unit consisting of the control circuit and the valve actuator.
- control ball valve (self-cleaning and not subject to calcareous deposits), manufactured with special tooling of the channels where the water flows thereby providing very efficient mixing.

On the output for the mixed water is inserted a well inside which is housed a temperature sensor (high-precision, rapid response thermistor).

An essential feature of MAS...electronic mixers is their rapid response to temperature variations.

The mixer compares the temperature of the water, measured by the sensor, with the value requested by the knob on the cover. According to the difference in temperature measured and to the Proportional Band, the controller processes the data and sends to the valve modulating control signals which optimizes the speed and the stability of the system.

This special type of control permits great stability even with very low consumptions of DHW.

The use of the recycle pump keeps at the right temperature the whole hydraulic distribution circuit, reducing the delay between the moment at which the user requests DHW and the moment of its arrival at the tap.

3. MODELS

Model	Power supply V~ (VA)	Electronic unit	Code	3 way control ball valve						
				DN inches	DN mm	Kvs m ³ /h	Nominal flow l/min	Equivalent number contemporary showers	Max Flow l/min	Min Flow l/min
MAS 615	230 (6)	MAS 600/E	MAS 615/V	1/2"	15	2.5	40	5	60	2
MAS 620	230 (6)	MAS 600/E	MAS 620/V	3/4"	20	5.0	70	8	100	3.5
MAS 625	230 (6)	MAS 600/E	MAS 625/V	1"	25	9.0	130	15	200	6
MAS 632	230 (6)	MAS 600/E	MAS 632/V	1"1/4	32	13.5	180	20	270	7
MAS 740	230 (9)	MAS 700/E	MAS 740/V	1"1/2	40	19.2	270	30	400	9
MAS 750	230 (9)	MAS 700/E	MAS 750/V	2"	50	28.6	390	43	600	12

N.B. – The nominal flow refers to a mean pressure of 4 bar and a pressure drop of the valve of about 20%.

- The maximum flow permits the supply of DHW even in the exceptional event of a very high contemporaneous level of use.
- The minimum flow is that which still guarantees control stability and accuracy.

4. EXAMPLES OF INSTALLATIONS

4.1 Installation with calorifier without recycle input

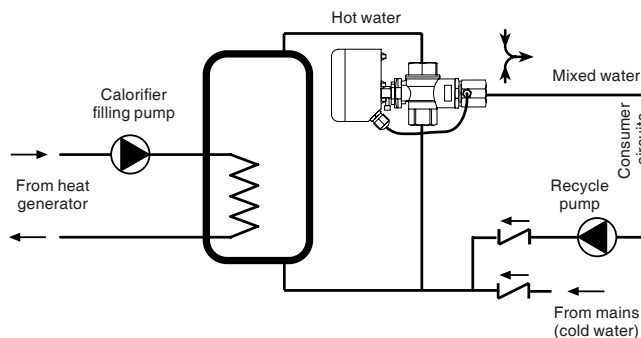

4.2 Installation with calorifier fitted with recycle input

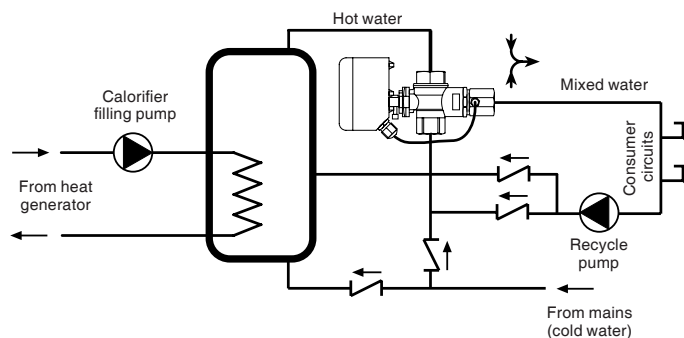

5. TECHNICAL DATA

• Controller

Power supply	230 V~
Frequency	50...60 Hz
Consumption :	
- MAS 6..	6 VA
- MAS 7..	9 VA
Rotation angle	90 °
Run time for 90° :	30 seconds
Setting range	30...70 °C
Materials:	
- Base	Nylon 66
- Cover	polycarbonate
Ambient temperature :	
- Operating	0...45 °C
- Storage	-20...60 °C

Ambient humidity
Protection

Class F DIN 40040
IP 55

• Valve

Test pressure	1000 kPa (10bar)
Working pressure	600 kPa (6bar)
Maximum differential pressure	600 kPa (6bar)
Fluid temperature	5...120 °C
Glycolate fluid (for special applications)	50% max.
Materials :	
- Valve body	nickel-plated OT58 brass
- Ball	hard-chromed OT58 brass
- Spindle	OT58 brass
- Ball gasket	PTFE (teflon)
- Spindle gasket	O-Ring viton

6. OVERALL DIMENSIONS

6.1 Electronic controller

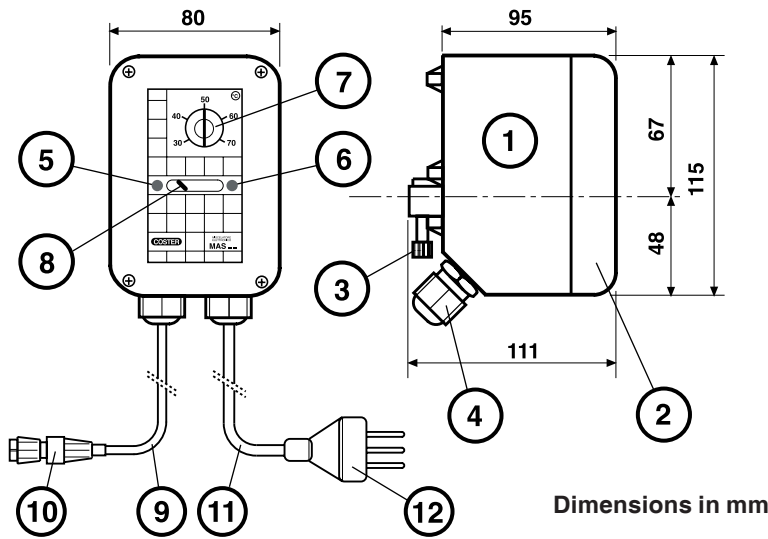

- 1 - Base
- 2 - Protective cover for printed circuit board
- 3 - Screws for securing coupling pins to the valve
- 4 - PG 11 cable entry gland
- 5 - Red mark (opens)
- 6 - Blue mark (closes)
- 7 - Desired temperature setting dial
- 8 - Valve position indicator
- 9 - Temperature detector connecting cable (30 cm)
- 10 - Connector for temperature detector
- 11 - Power supply cable (1 metre)
- 12 - Power supply plug

Dimensions in mm

6.2 Overall dimensions & weight

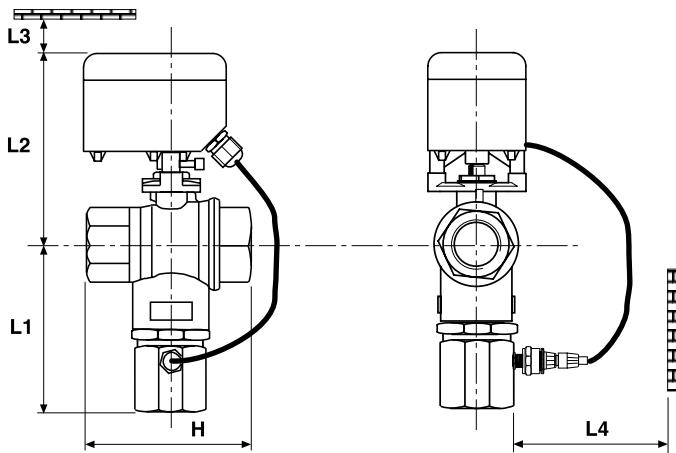

Model	DN	L1 mm	L2 mm	L3 min mm	L4 min mm	H mm	Weight Kg
MAS 615	1/2"	75	146	30	100	64	1.5
MAS 620	3/4"	79	151	30	100	74	1.7
MAS 625	1"	94	156	30	100	89	2.2
MAS 632	1 1/4"	106	161	30	100	100	2.8
MAS 740	1 1/2"	113	167	30	100	110	3.3
MAS 750	2"	136	178	30	100	130	4.8

7. PRESSURE DROP CHART

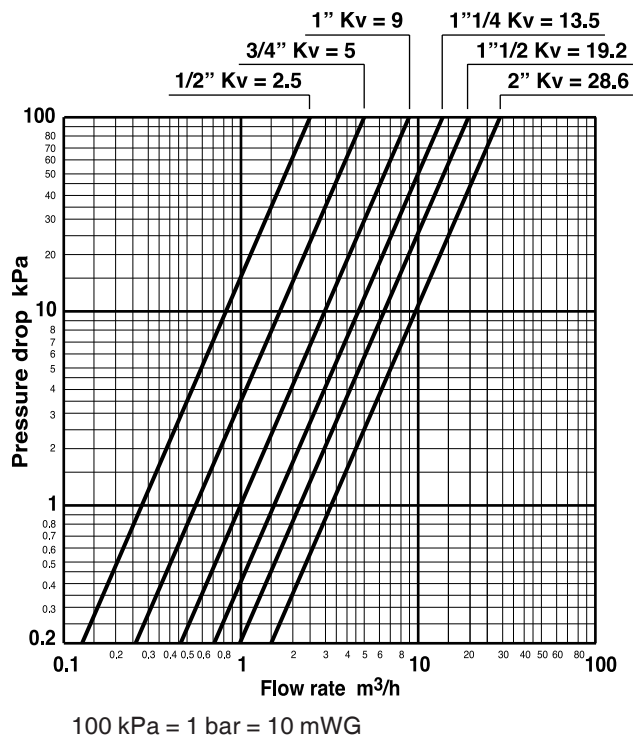

8. INSTALLATION

8.1 Installing the valve

The valve can be installed in any position except that with the control spindle facing downwards.

To one of the two opposite ports (it does not matter which) is connected the hot water from the calorifier, and to the other is connected the mixture cold water - recycle.

From the central port, where the pocket containing the temperature sensing element is inserted, flows the mixed hot water directed to the consumer circuit.

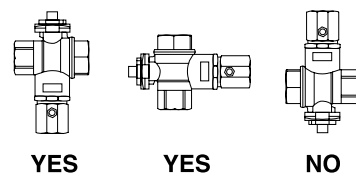

8.2 Positioning the valve spindle

When the valve has been installed hydraulically, position the control spindle so that the entry port for hot water coming from the calorifier is open, as shown in the following diagrams.

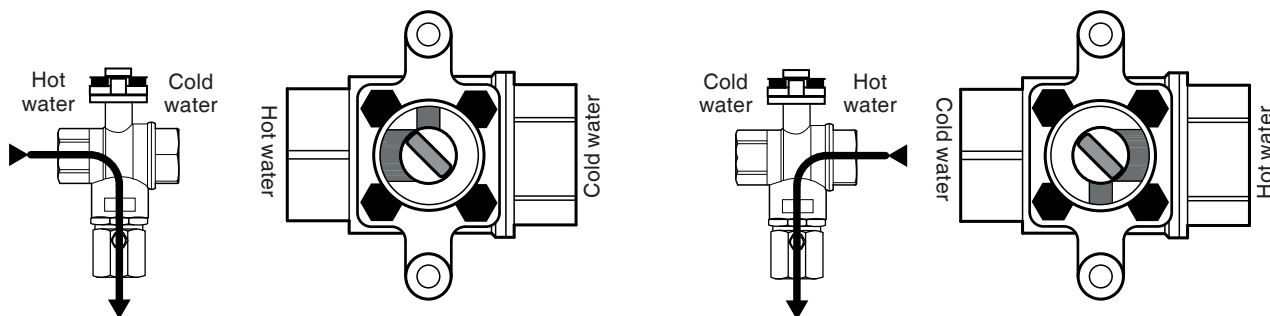

8.3 Coupling the controller to the valve

The controller is supplied in the “open” position, corresponding, hydraulically, to the open position for the input for water coming from the calorifier. The valve position indicator, seen in the slot in the diagram (6.1.8) must be turned in the direction of the red mark (6.1.5).

If it is not in this position, plug in the power supply cable to a 230 V~ earthed mains socket: the controller should open. Next, loosen the two controller securing screws (2), couple the housing on the securing spigots (4), insert the controller spindle (3) in the valve spindle (5) and then secure it by tightening the two securing screws.

Warning: install the controller on the valve so that the electric cable entry glands are not facing upwards. This is to ensure that water drops from condensation or falling from overhanging objects might, over time, penetrate to the inside of the electronic controller..

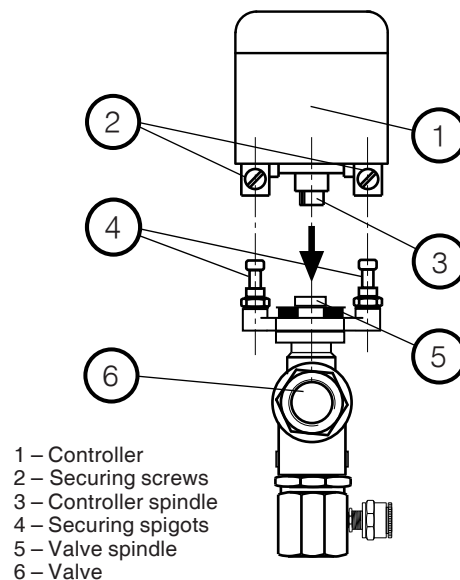

8.4 Temperature detector

To connect the controller to the temperature detector:

- after having found the correct position of the insertion guide, push the female connector (1) of the controller into the fixed male union (3) of the pocket,
- while rotating it slowly push the securing ring nut (2) until it is above the fixed male union,
- rotate the securing ring nut (2) clockwise (for about half a turn) until you feel it snap into position.

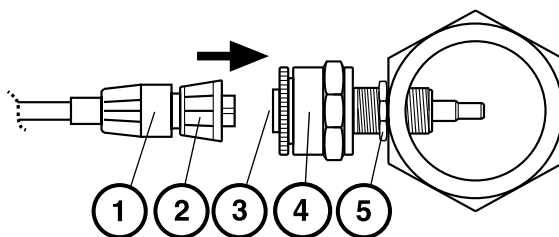

Should it be necessary to replace the sensor pocket, position the securing ring nut at the same distance as that mounted so that the sensing element is in the centre of the flow inside the valve.

9. TESTING

After having mounted the controller on the valve (8.3) and connected the temperature detector (8.4), plug in the power supply to the mains. The temperature of the water coming from the calorifier must be at least above 35°C. Proceed as follows:

- set the desired temperature dial to minimum (30°C): the controller should close the valve completely (the indicator moves towards the blue mark) and the mixed water should be cold.
- set the desired temperature dial to maximum (70°C): the controller should open the valve completely or start making adjustments if the calorifier temperature exceeds 70°C (the indicator moves towards the red mark) and the mixed water should be hot.
- set the temperature dial to the desired temperature (generally between 47°C and 50°C = black zone of scale): check that the temperature of the mixed water is at the desired value.

If the test gives a negative result first of all check that the installation is correct (see section 8).

10. REPLACEMENT OF ELECTRONIC CONTROLLERS MAS 66/E AND MAS 77/E

10.1 Replacement of MAS 66/E with MAS 600/E

If you want to replace a MAS 66/E electronic controller (which controls MAS 660-661-662-663) by electronic controller MAS 600/E you must:

- replace the existing pocket with a new pocket and temperature detector,
- position the lock nut so that the extremity of the pocket, where the sensing element is housed, is in the centre of the flow of water inside the valve. The pocket must be sealed to the valve with a hydraulic seal (Teflon or hemp) to ensure there is no water leakage,
- install MAS 600/E controller. Connect the female union of the controller to the male union of the sensor pocket as described in section 8.4.

10.2 Replacement of MAS 77/E by MAS 700/E

If you want to replace MAS 77/E electronic controller (which controls MAS 770-771) by a MAS 700/E unit, you must :

- replace the existing pocket as described in section 10.1 (replacement of MAS 66/E by MAS 600/E),
- on the valve base, insert in the two holes for securing the actuator the two spacing collars supplied with a MAS 700/E
- install MAS 700/E controller. Connect the female union of the controller to the male union of the sensor pocket as described in section 8.4,
- the valves of MAS 770-771 had, as output for mixed water, not the central port but one of the two opposite ports; therefore, according to the type of installation, the correct direction of rotation of the controller can be the factory setting or the opposite,
- if it should be necessary to invert the direction of rotation of the control of the valve output, set the desired temperature dial to minimum (in order to have a definite reference position); then, after having loosened the four securing screws, remove the cover and handle. Move the dip-switch on the printed circuit to the right (see diagram below) and then replace the cover and the handle (which should still be at the minimum position), taking care that the waterproofing seals are not damaged.

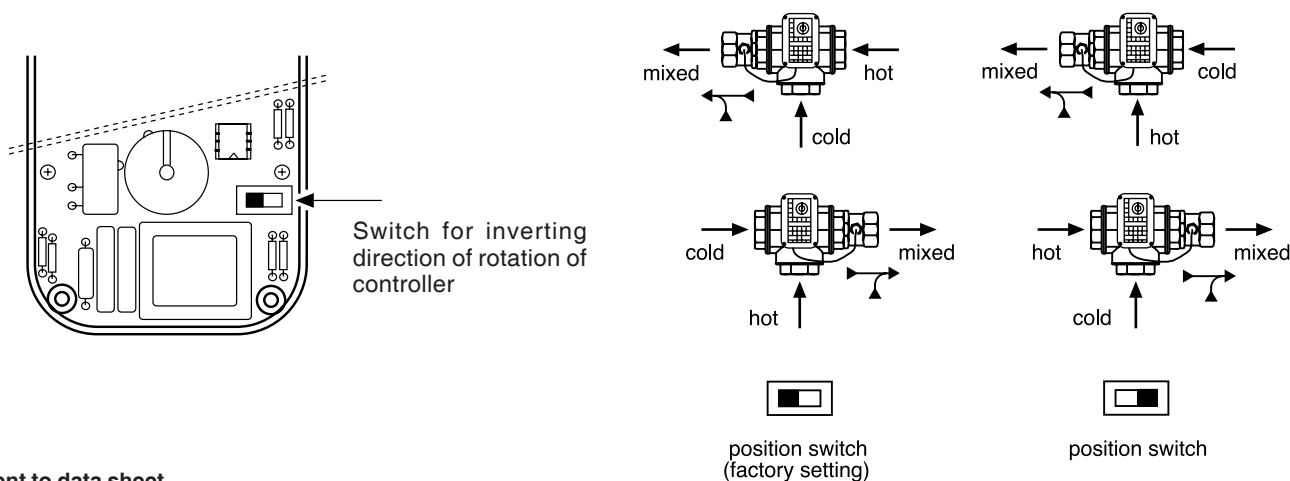

Amendment to data sheet

Date	Revision No.	Page	Section	Details of amendment
02.10.07 MZ	01	3	8.2. Positioning the valve spindle	Update valve spindle diagram
03.11.08 MZ	02	2	6.2 Overall dimensions & weight	Update overall dimensions
27.02.09 AM	03	1	3. MODELS	Update table



Head Office & Sales
 Via San G.B. De La Salle, 4/a Tel. +39 022722121
 20132 - Milano Fax +39 022593645
 Orders Fax +39 0227221239
 Reg. Off. Central & Southern
 Via S. Longanesi, 14 Tel. +39 065573330
 00146 - Roma Fax +39 065566517
 Shipping
 Via Gen. Treboldi, 190/192 Tel. +39 0364773200
 25048 - Edolo (BS) Tel. +39 0364773202
 E-mail: info@coster.eu Web: www.coster.eu



D 33192

