

TEMPERATURE & HUMIDITY CONTROLLER FOR AIR HANDLING UNITS

OPTIONAL

C ← BUS

XTU 618 Eng.



Translator's note :

Throughout this document the terms "discharge air" and "flow" have the same meaning and in the diagrams on pages 8 and 9 are both represented by the letter "m"

- **Control of ambient temperature & humidity with season switching**
- **Communication systems:**
 - C-Bus: XTU 614 is already wired for Telemangement
 - To enable Telemangement use **C-Bus Plug-in, model ACB 460**, to be ordered separately as an accessory.
- **Power supply 230 V AC (or 240 V AC for UK market); DIN rail mounting**

1. APPLICATION

XTU 618 controller is designed for the winter & summer control of ambient temperature and humidity and/or discharge air in air handling plants consisting of:

- 1 battery hot/chilled water with 3-wire modulating control or electric batteries with 1- or 2-stage On-Off control or direct expansion batteries with 1- or 2 -stage On-Off control
- 1 adiabatic humidification unit with On-Off control

By means of the C-Bus connection the controller can be included in a Telemangement system.

2. FUNCTIONS

The main functions of XTU 618 are:

- Winter and summer control of ambient temp. or discharge air with :
 - 3-wire modulating control or On-Off in two stages
 - winter and summer minimum and maximum limits of discharge air temperature
 - maximum differential between winter discharge air and ambient temperatures to avoid stratification of hot air.
 - maximum differential between summer discharge air and ambient temperatures to avoid condensation in discharge air duct.
- Winter control of ambient humidity by On-Off control of humidification unit.
- On-Off control of fan and plant pump by timed programme.
- Three-wire On-Off control for plant season switching.
- Season switching of controller functions:
 - manual from display;
 - by remote control (manual switching or control from other devices);
 - automatic in relation to season periods or to outside temperature.
- Winter battery frost protection control.
- Daily and weekly timed programming.
- Programming with dates: 15 holiday periods for the winter season and 15 for the summer season.
- Adjustment of temperature setting by remote control.
- Changes to timed programme in use by remote control.
- One On-Off input for signalling status or alarm situation.
- Alarms for short or open detector circuits and for system and equipment malfunctioning.

3. ACCESSORIES

No.	Description	Type	Range	Sensing element t°	Code	Data Sheet
1	Duct mounting extract air temp. detector or room temperature detector	STA 010 SAB 010	0...40 °C 0...40 °C	NTC 10 kΩ NTC 10 kΩ	B3 B3	N 150 N 111
1	Duct mounting discharge air temp. detector	STA 010	0...60 °C	NTC 10 kΩ	B1	N 150
1	Duct mounting outside air temp. detector or wall mounting outside air temp. det.	STA 001 SAE 001	-30...+40 °C -30...+40 °C	NTC 1 kΩ NTC 1 kΩ	B2 B2	N 150 N 120
1	Relative humidity & room temp. detector or duct mounting rel. humidity detector	SAU 012 SUR 012	0...40 °C ; 20...80 % 20...80 %	NTC 10 kΩ -	B3-B6 B6-B7	- -
1	Frost protection cable-type temp. detector or frost prot. immersion temp. detector	SAF 010 SIH 010	0...40 °C 0...40 °C	NTC 10 kΩ NTC 10 kΩ	B4 B4	N 145 N 140
1	Temperature set point adjuster	CDB 100	± 5 °C	-	Rt°	N 710
1	Remote control for modifying programme in use	CDB 333	-	-	R	N 710
1	Accessories for Telemangement Plug-in for communicating via C-Bus	ACB 460	-	-	-	-

4. TECHNICAL DATA (default values in bold type)

• Electrical

Power supply	230 V AC \pm 10% or 240 V AC for UK market
Frequency	50 ... 60 Hz
Consumption	5 VA
Protection	IP40
Radio disturbances	VDE0875/0871
Vibration test	with 2g (DIN 40 046)
Voltage-free output contacts:	
Maximum switching voltage	250 V ~
Maximum switching current	5 (1) A
Construction standards	Italian Electrotech. Committee CEI
Data storage period	5 years
Software	Class A

• Mechanical

Case	DIN 6E module
Mounting	on DIN 35 rail
Materials:	
Base	NYLON
Case	ABS
Room temperature:	
Operation	0 ... 45°C
Storage	- 25 ... + 60°C
Room humidity	Class F DIN 40040
Dimensions	105 x 115 x 71.5
Weight	1.0 kg

• Programmes & winter periods

Daily programmes	1...3
Daily times	2...6
Weekly programmes	1
Holiday periods	0...15

• Programmes & summer periods

Daily programmes	1...3
Daily times	2...6
Weekly programmes	1
Holiday periods	0...15

• Setting ranges

Winter temperatures:	
Desired room day (B3 or B1+B3)	0... 20 ...40 °C
Desired room night (B3 o B1+B3)	0... 16 ...40 °C
Desired room Frost Protection (B3 or B1+B3)	0... 6 ...40 °C
Desired day flow (B1)	0... 20 ...60 °C
Desired night flow (B1)	0... 16 ...60 °C

Minimum limit flow (B1+B3)	0... 18 ...60 °C
Maximum limit flow (B1+B3)	0... 50 ...60 °C
Limit flow – room (B1+B3)	0... 40 ...60 °C
Design outside (B1+B2)	- 30...- 10 ...+40 °C
Design flow (B1+B2)	0... 50 ...60 °C
Battery Frost Protection (B4)	2... 7 ...40 °C
Summer temperatures:	
Desired room day (B3 o B1+B3)	0... 25 ...40 °C
Desired day flow (B1)	0... 25 ...60 °C
Minimum limit flow (B1+B3)	0... 10 ...60 °C
Maximum limit flow (B1+B3)	0... 25 ...60 °C
Limit room – flow (B1+B3)	0... 40 ...60 °C
Design outside (B1+B2)	- 30...+ 35 ...+40 °C
Design flow (B1+B2)	0... 10 ...60 °C
Compensation from outside temp. (B3 + B2)	0... 6 ...60 °C

Proportional band temperatures (base value):	
Winter room (B3 or B1+B3)	\pm 1... \pm 2 ... \pm 30 °C
Winter flow (B1)	\pm 1... \pm 10 ... \pm 30 °C
Multipliers Proportional bands temperatures:	
Winter flow (B1+B3)	Pb amb. x 0.5... 5 ...9.5
Summer temperatures	Pb win. x 0.5 ...9.5
Integral time	0... 10 ...255 min.

Temperature control output:	- valve (3-wire modulating)
	- On-Off in 2 stages
Run time modulating valve	30... 60 ...3,600 s
Desired winter humidity	10... 50 ...90 %
Humidity differential	0.5... 5 ...30 %
Delay winter switching	1... 24 ...60 h
Delay summer switching	1... 4 ...60 h

• Setting alarms

Telemangement (setting from PC):	
Alarm call attempts	1... 5 ...255
Interval between alarm calls	2... 10 ...255 min
Alarms (setting from PC):	
Threshold flow temp. diff.(B1)	0... 5 ...99 °C
Delay diff. flow temp.	2... 30 ...255 min
Threshold room temp. diff. (B3)	0... 1 ...99 °C
Delay diff. room temp.	2... 30 ...255 min
Delay intervention Frost protection temp. (B4)	2... 5 ...255 min
Threshold diff. humidity (B6)	0... 10 ...100 %
Delay diff. humidity	2... 30 ...255 min

WARNING :

In the presence of electrical disturbances the outputs of the controller may change status but this will be automatically

5. OVERALL DIMENSIONS

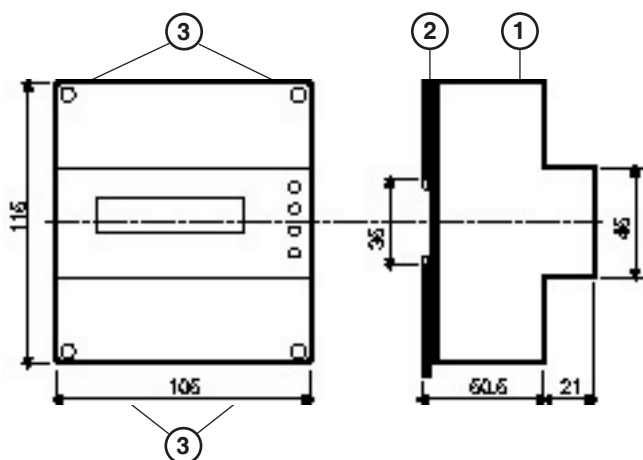

- 1 – Protective cover for electronic components
- 2 – Support base with transformer, relay and terminal blocks
- 3 – Screws for securing base and cover
- 4 – DIN rail securing elements
- 5 – DIN rail release lever

6. FRONT PANEL

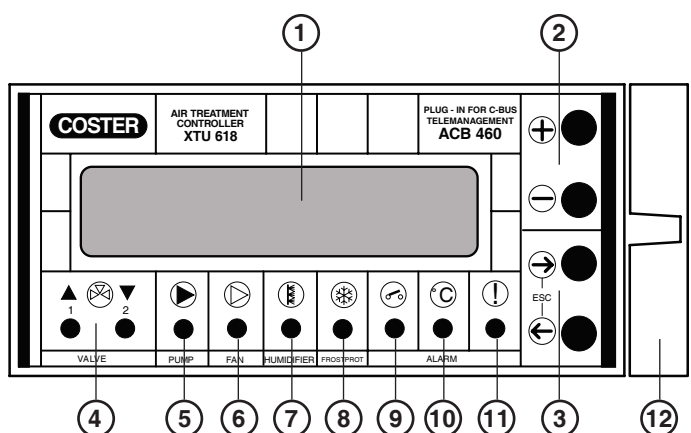

- 1 – Backlighted alphanumeric display
- 2 – + and - keys
- 3 – ← and → keys
- 4 – Valve LEDs
- 5 – Pump LED
- 6 – Fan LED
- 7 – Humidifier LED
- 8 – Frost protection LED
- 9 – On-Off alarms LED
- 10 – Measurement alarms LED
- 11 – Fault LED
- 12 – Plug-in type ACB 460 for C-Bus communication

7. WIRING DIAGRAMS

7.1 Control 3-wire modulating valve

- B1 – Discharge air 0...60 °C temp. detector
- B2 – Outside temp. detector
- B3 – Room temp. or extract air 0...40 °C detector
- B4 – Battery frost protection 0...40 °C detector
- B6 – Room humidity or extract air 0...100% active detector
- cs – Season switch
- k1 – On-Off alarm switch
- Mp – Plant pump
- Mu – On-Off humidifier
- Mv – Fan
- R – Remote control for modifying programmes
- Rt° – Desired temperature set point adjuster
- Y – Regulating valve
- Ycs – Season switching valve :
 Winter = 7-6 closed; 7-5 open
 Summer = 7-6 open; 7-5 closed
- C-Bus – Transmission data via Telemanagement; C-Bus is enabled using the Plug-in type ACB 460

M5.2
 Control : VALVE
 Run Time : xxxs

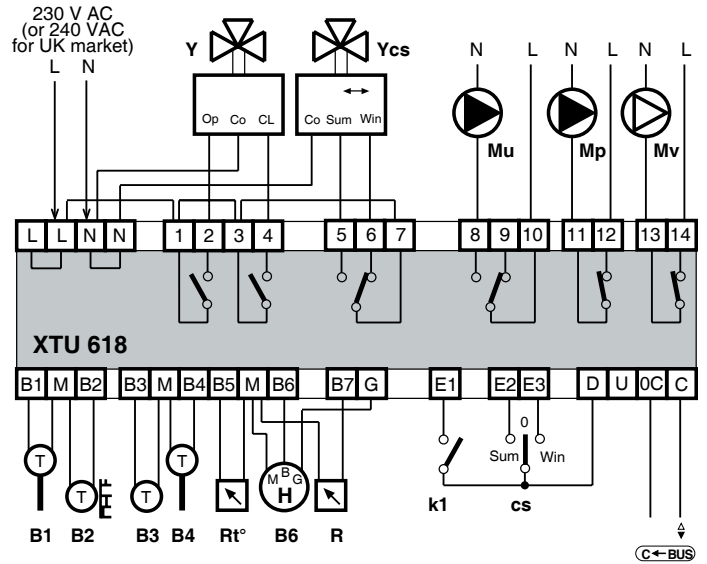

7.2 Electric battery or direct expansion control

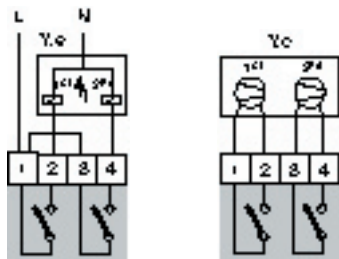

M5.2
 Control : On-Off

7.3 Connection ambient humidity-temp. detector SAU 012

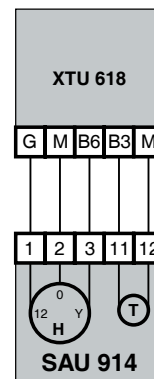

8. WIRING

Proceed as follows:

- Separate the base from the cover
- Install the base on the DIN rail and check that it is firmly anchored by the securing elements (5.4)
- Carry out the wiring as in the diagram in compliance with the regulations in force and using:
 - 1.5 mm² cables for power supply and relay control outputs
 - 1 mm² cables for the detectors and remote control
 - 1 mm² cables for C-Bus. For length limits see data sheet T 021.
- Apply power (24 V~) and check its presence across terminals 24 and 0.
- Remove power, replace cover on base/terminal block and secure it with the four screws supplied (5.3).

You are advised not to insert more than two cables in a single terminal of the controller and, if necessary, to use an external junction box.

9. SITING CONTROLLER & DETECTORS

9.1 Controller

The controller must be placed in a dry environment, in compliance with the relevant environmental conditions described under "Technical Data". If placed in an environment classified as "hazardous" it must be installed on a control panel constructed in accordance with current regulations in force according to hazard class. The controller may be installed on a DIN rail or in a standard DIN cabinet.

9.2 Discharge air temperature detector B1 (STA 010)

This must be installed downstream of the discharge fan.

9.3 Outside temperature detector B2

STA 001 for air duct : Can be used in plants with a constant inflow of outside air.

It must be installed upstream of the outside air dampers near the air intake.

SAE 001 for wall mounting : It must be used in plants where the input of outside air is not constant. It must be installed outside the building on the north or north-west side, at least three meters from the ground, shaded from the sun and as far as possible from windows, doors, chimneys or other direct thermal disturbances.

9.4 Ambient temperature or extract air B3 or temperature and humidity detector B3 + B6

Ambient SAB 010 or SAU 012: This must be installed at a point that represents the mean temperature and/or humidity of a significant space (e.g. living room) at a height of 1.5... 1.6 meters from the floor, on an internal wall and as far as possible from windows, doors and sources of heat; corners, shelving and curtains should be avoided.

Extract air STA 010: must be installed upstream of the extract fan.

9.5 Air duct humidity detector B6 (SUR 012)

Extract air: must be installed upstream of the extract fan.

Discharge air: must be installed downstream of the discharge fan.

9.6 Battery Frostprot temperature detector

SAF 010 : The sensing element of the detector must be installed downstream of the battery (hot air side), in direct contact with the plates in the coldest zone of the battery (near the water outlet).

STA 010 : This must be utilised only when SAF 010 cannot be installed in contact with the battery and has to be installed on the return pipe of the battery and as near as to it as possible.

10. COMMUNICATION

10.1 C-Bus Telemangement Communication (for more detailed information please see Technical Sheet T 021)

XTU 618 provides:

- remote Telemangement by means of **C-Bus Plug-in type ACB 460**
- local communication (e.g. setting via PC) with Test Plug-in ACX 232

Telemangement is two-way, with one or more local PC(s) and/or a remote central computer via telephone network.

From the PC(s) it is possible:

- to view and change data and values entered on the controller display pages, and the configuration data dedicated to Telemangement only (see 4. Technical Data)
- check the operational status of the site components (pumps, accessories in general)
- to acquire system-generated alarms
- to view sensor readings (temperatures: outside, room, flow, etc.)

10.2 C-Bus wiring for local or remote Telemangement

Each controller must be equipped with the correct model of the C-Bus Plug-in of the required type for the controller in question

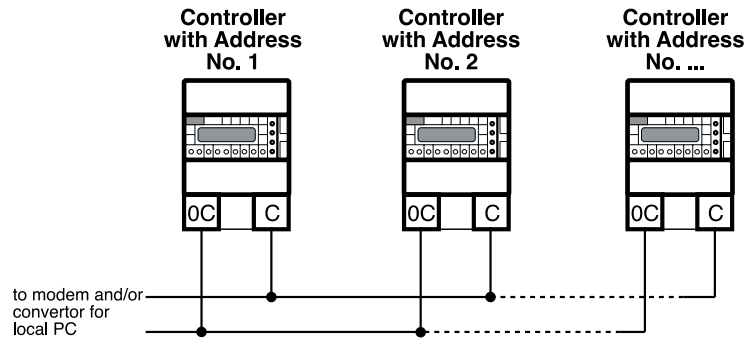

10.3 Connection to PC for local communication via test Plug-in ACX 232

Extract the C-Bus Plug-in and insert the test Plug-in ACX 232; use a standard cable to connect the RS232 plug to the PC (the cables are included in the "HANDY KIT".

If the PC has only USB sockets use a standard RS232 to USB conversion cable.

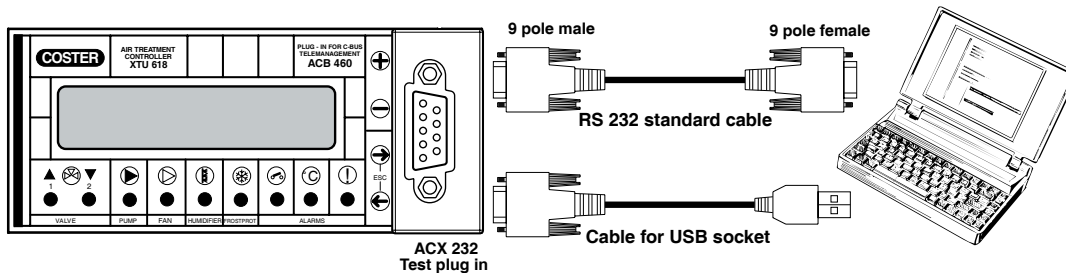

ACCESSORIES:

- Test Plug-in = **ACX 232**
- handy kit = **KIT RS 232**

The "handy kit" contains the 2 cables & other useful accessories.

Observations : - Before communicating, ensure that the address entered in the controller is the address with which you wish to communicate via PC.

- It is advisable to use a portable PC powered by battery with the connection to 230 Volts unplugged (or 240 Volts for UK market), since the earth (0 volts) of the controller is connected to that of the RS 232 and so to that of the PC. By connecting the two earths together the currents may be dispersed, if the earths have not been well made and if the PC has its 0 volt connected directly to the central pole of the plug (as is usual)

11. EXAMPLES OF PLANTS

11.1 – Modulating control of the valve for winter heating battery and summer cooling with winter frost protection control – On-Off control of adiabatic humidification unit

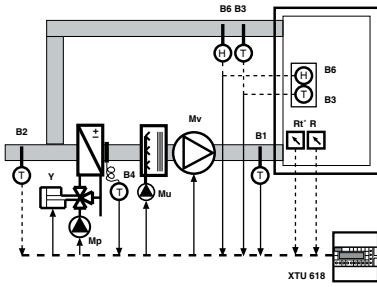

- B1 – Flow temp. detector
- B2 – Outside temp. detector (for compensation)
- B3 – Room or extract air temp. detector
- B4 – Battery frost protection temp. detector
- B6 – Room humidity or extract air detector
- cs – Season switch (optional)
- k1 – On-Off alarm switch (optional)
- Mp – Timed control plant pump
- Mu – On-Off control humidifier
- Mv – Timed control fan
- Rt° – Temperature set point adjuster (optional)
- R – Programme selector (optional)
- Y – Modulating control heating/cooling

M5.1	M5.3	M5.2
Detectors Set. 1 2 3 4 5 6 7	Season Switching XXXXXXXXXX	Control : VALVE Run Time : xxxs

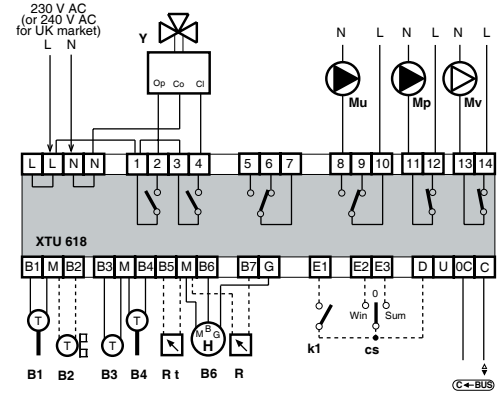

11.2 – Modulating control of battery valve for winter heating and summer cooling with winter frost protection control – Season switching of diverting valve for hot and cold circuits – On-Off control adiabatic humidification unit

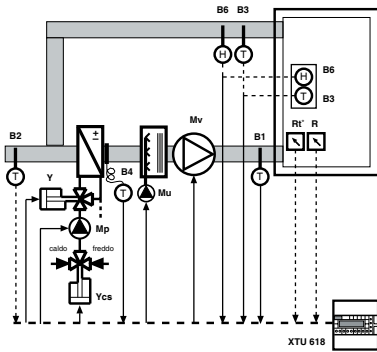

- B1 – Flow temp. detector
- B2 – Outside temp. detector (for compensation)
- B3 – Room or extract air temp. detector
- B4 – Battery frost protection temp. detector
- B6 – Room humidity or extract air detector
- cs – Season switch (optional)
- k1 – On-Off alarm switch (optional)
- Mp – Timed control plant pump
- Mu – On-Off control humidifier
- Mv – Timed control fan
- Rt° – Temperature set point adjuster (optional)
- R – Programme selector (optional)
- Y – Modulating control heating/cooling
- Ycs – Season switching diverting valve

M5.1	M5.3	M5.2
Detectors Set. 1 2 3 4 5 6 7	Season Switching XXXXXXXXXX	Control : VALVE Run Time : xxxs

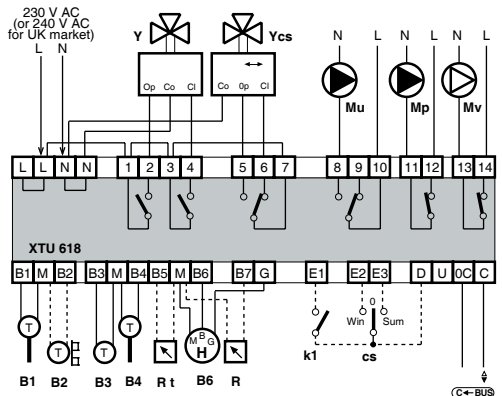

11.3 – Modulating control battery valve for winter heating and summer cooling with winter frost protection control – Season control of heating pump – On-Off control adiabatic humidification unit

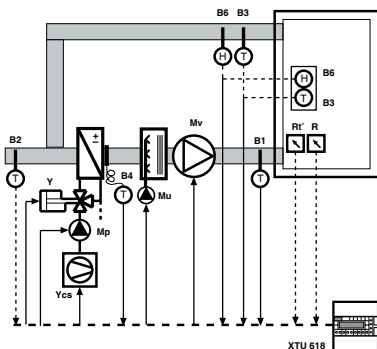

- B1 – Flow temp. detector
- B2 – Outside temp. detector (for compensation)
- B3 – Room or extract air temp. detector
- B4 – Battery frost protection temp. detector
- B6 – Room humidity or extract air detector
- cs – Season switch (optional)
- k1 – On-Off alarm switch (optional)
- Mp – Timed control plant pump
- Mu – On-Off control humidifier
- Mv – Timed control fan
- Rt° – Temperature set point adjuster (optional)
- R – Programme selector (optional)
- Y – Modulating control heating/cooling
- Ycs – Season control heat pump

M5.1	M5.3	M5.2
Detectors Set. 1 2 3 4 5 6 7	Season Switching XXXXXXXXXX	Control : VALVE Run Time : xxxs

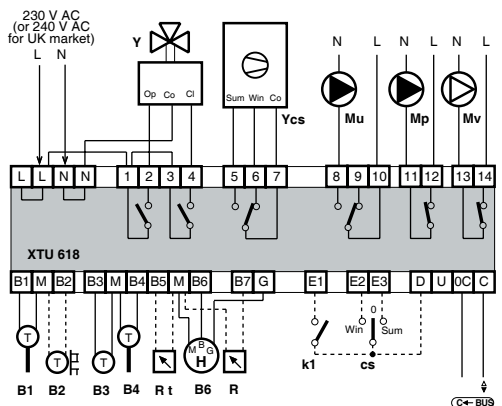

11.4 – On-Off control in 1 or 2 stages of heat pump for winter heating and summer cooling with winter frost protection control and season switch

– On-Off control of adiabatic humidification unit

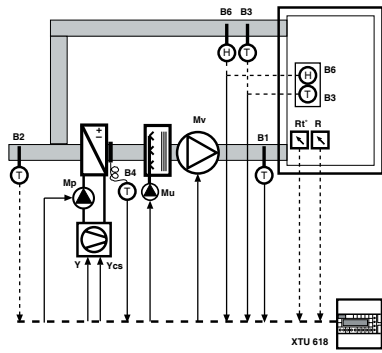

- B1 – Flow temp. detector
- B2 – Outside temp. detector (for compensation)
- B3 – Room or extract air temp. detector
- B4 – Battery frost protection temp. detector
- B6 – Room or extract air humidity detector
- cs – Season switch (optional)
- k1 – On-Off alarm switch (optional)
- Mp – Timed control plant pump
- Mu – On-Off control humidifier
- Mv – Timed control fan
- Rt° – Temperature set point adjuster (optional)
- R – Programme selector (optional)
- Y – On-Off control heat pump in 1 or 2 stages
- Ycs – Season control heat pump

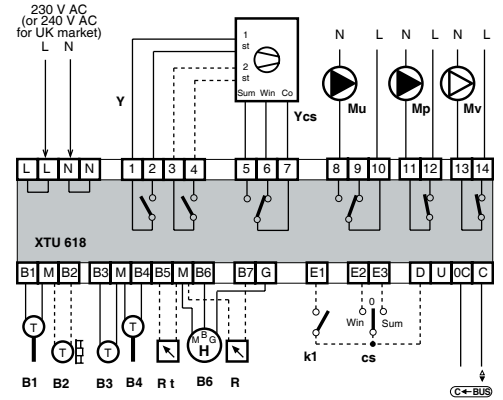

M5.1	M5.3	M5.2
Detectors Sect. 1 2 3 4 5 6 7	Season Switching XXXXXXXXXX	Control: ON-OFF

11.5 – On-Off control in 1 or 2 stages of heat pump for winter heating and summer cooling with direct expansion and season switch

– On-Off control of adiabatic humidification unit

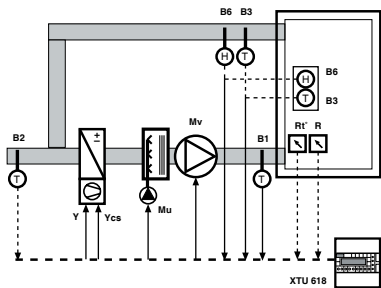

- B1 – Flow temp. detector
- B2 – Outside temp. detector (for compensation)
- B3 – Room or extract air temp. detector
- B6 – Room or extract air humidity detector
- cs – Season switch (optional)
- k1 – On-Off alarm switch (optional)
- Mu – On-Off control humidifier
- Mv – Timed control fan
- Rt° – Temperature set point adjuster (optional)
- R – Programme selector (optional)
- Y – On-Off control heat pump in 1 or 2 stages
- Ycs – Season control heat pump

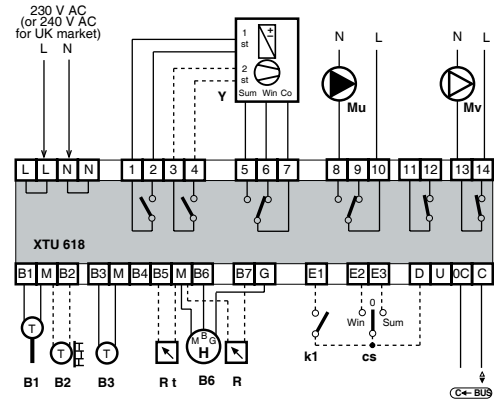

M5.1	M5.3	M5.2
Detectors Sect. 1 2 3 - 5 6 7	Season Switching XXXXXXXXXX	Control: ON-OFF

12. OPERATION

XTU 618 is a digital controller with microprocessor for automising air handling plants by:

- control of room and/or flow temperature.
- control of relative humidity by control of adiabatic humidifier.
- winter control of battery frost protection temperature.
- programmed times control of plant fan and pump.

To adapt the controller to the plant requirements you have to configure it by replacing the line of dashes with the numbers of the B.. inputs used to connect the detectors and the remote controls.

M5.1

Detectors Set.
- - - - -

13. TEMPERATURE CONTROL

Temperature control can function in the following ways:

M5.1

Detectors Set.
- - 3 - - - -

- Only room or extract air detector **B3**: fixed point control of winter and summer room temperatures.

Detectors Set.
1 - - - - -

- Only discharge air detector **B1**: fixed point control of winter and summer flow temperatures.

Detectors Set.
1 - 3 - - - -

- Room or extract air detector **B3** and discharge air detector **B1**: control of winter and summer flow temperatures in relation to the variation in room temperature.

13.1 Desired temperatures and operational mode

The desired temperatures are given separately in the TEMPERATURES & HUMIDITY menu for:

- the winter season (M1.1...5):

Day T. ambient Winter 20.0c	Night T. ambient Winter 16.0c	FrostPr. ambient Winter 20.0c
Day Flow Temp. Winter 20.0c	Night Flow Temp. Winter 16.0c	

- the summer season (M1.8-9):

Day T. ambient Summer 25.0	Day T. ambient Summer 25.0c
-------------------------------	--------------------------------

The desired temperatures are assigned to the operating periods when setting the daily programmes in the menus WINTER TIMES and SUMMER TIMES (see paragraph 18.1)

The operating mode of the controller is shown on a page of the display and depends on

the current season and the programme in use chosen in

M0.2 Site----- Win: DAILY 1	or in	M0.4 Site----- Sum: DAILY 1
-----------------------------------	-------	-----------------------------------

- Win = winter period
- Sum = summer period
- Current mode: for winter period: DAY TEMP20.0c; NIGHT TEMP16.0c; DAY FLOW20.0c; NIGHT FLOW T16.0c; FROSPROT6.0c; OFF.
- for summer period: DAY TEMP25.0c; DAY FLOW25.0c; OFF.
- Dt - - . - : Desired for temperature current mode.
- Var + - . - c : Manual adjustment of desired temperature ($\pm 9^\circ\text{C}$).

M0.3

WIN:DAY T 20.0c
Dt20.0c Var±0.0c

If the set point adjuster **Rt**^o is connected, it is possible to adjust from a distance the value of the temperature desired by the current mode.

The value of the adjustment made is shown on a page of the display.

M0.5

Outside Adjuster
Desir.t : ± 0.0c

13.2 Proportional band & Integral time

The basic parameters of temperature regulation, **Proportional band** and **Integral time**, refer to the **winter** regulation (Ambient, if connected only B3 or B1+B3 or Flow, if connected only B1) and can be adjusted in the SETTINGS menu.

M4.1

Ambient Temp.
Prop.Band: 2.0c
Ambient Temp.
Prop.Band: 10.0c

The parameter Proportional band (in $\pm^\circ\text{C}$) is adapted to other temperature controls by means of fixed **multipliers**.

Example of Pb multipliers with B3 or B1 and B3 connected

M4.1
Ambient Temp.
Prop.Band: ± 2.0c

- Pb Flow heating (B1 + B3) = Pb Ambient heating x **5.0** ($= \pm 10^\circ\text{C}$)
- Pb Ambient cooling (B3 or B1+ B3) = Pb Ambient heating **0.5** ($= \pm 1^\circ\text{C}$)
- Pb Flow cooling (B1 + B3) = Pb Ambient heating x **2.5** ($= \pm 5^\circ\text{C}$)

Example of Pb multipliers with only B1 connected

M4.1
Flow temperature
Prop.Band: ±10.0c

Pb Flow cooling (B1) = Pb Flow heating x **0.5** ($= \pm 5^\circ\text{C}$)

M4.2

Ambient Temp.
Integral Time: 10m

The parameter Integral time (in minutes) is used for all the temperature controls.

13.3 Control with only ambient detector (B3) or only discharge air detector (B1)

M5.2

Control : VALVE
Run Time : 60s

The controller compares the temperature desired by the programme in use, according to the current season, with the temperature measured by detector B1 or B3 and operates the controls according to the difference measured and the values set:

- Control : VALVE = 3-wire modulating control
ON-OFF = On-Off control in two stages
- Run Time : x x s = time for a complete run by valve actuator, indispensable for the correct control operation if VALVE.

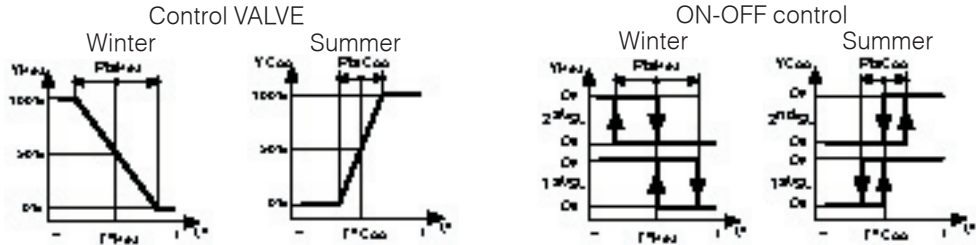

13.4 Control with ambient or extract air detector (B3) or discharge air detector (B1)

M4.3

Flow Heating T.
Min: 18c Max: 50c

M4.7

Cooling Flow
Min: 10c Max: 25c

M4.4

HeatingLimit Max
Flow-Amb : 40c

M4.8

CoolingLimit Max
Amb-Flow: 40c

The controller compares the temperature desired by the programme in use, according to the season period, with the temperature measured by the detector B3 and calculates the **desired discharge air temperature** according to the difference measured and the values set:

- Min : -- cMax : -- C = minimum and maximum limits of discharge air temp.; these establish the Proportional band range of ambient temperature.

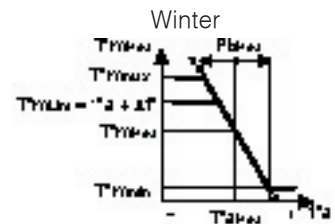

To avoid the **stratification of the hot air in the winter** period it is possible to set a maximum temperature differential between calculated flow and actual ambient.

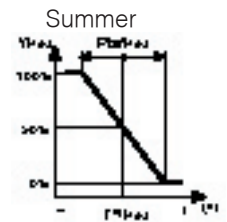

To avoid **condensation in the discharge air duct** in the summer period it is possible to set a maximum temp. differential between calculated flow and actual ambient.

M5.2

Control : VALVE
Run Time : 60s

The controller compares the **desired discharge air temperature** with the temperature measured by detector B1 and, according to the difference measured and values set, produces appropriate control action:

- Control : VALVE = 3-wire modulating control
ON-OFF = On-Off control in two stages
- Run time : x x s = time for a complete run by valve actuator, indispensable for the correct control operation if VALVE.

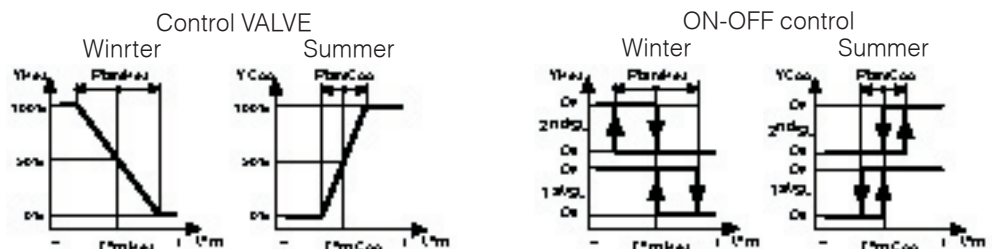

14. OUTSIDE TEMPERATURE COMPENSATION

The compensation functions are enabled only if the outside detector B2 is connected. These functions can be:

- Climatic compensation of the desired discharge air temperatures for heating and cooling.
- Summer compensation of ambient or discharge air temp. required by cooling.

14.1 Climatic compensation of desired discharge air temperatures for heating and cooling

M5.1

Detectors Set .
1 2 - - - -

This function can be used only if detectors B1 and B2 are connected and detector B3 is not connected. It is useful when the primary air plant, besides ensuring change of air, has to provide for ambient air dispersion.

M4.5

Clim.Heating :NO
Opt:-10c Ftp:50c

The controller increases the discharge air temperature required by Heating when the outside temperature falls, in accordance with the data set:

- Clim. Heating. :NO = function excluded
YES = function enable
- Opt : xx c = winter design outside temp.
- Ftp : xx c = winter design discharge air temp.

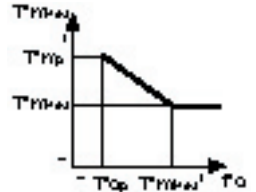

M4.9

Clim.Cooling. :NO
Opt:+35c Fpt:10c

The controller reduces the desired cooling discharge air temperature as the outside temperature increases according to the data set:

- Clim. Heating. :NO = function excluded
YES = function active
- Opt : xx c = summer design outside temp.
- Ftp : xx c = summer design discharge air temp.

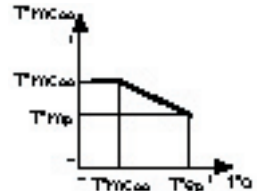

14.2 Summer compensation of ambient temperature

M5.1

Detectors Set .
1 2 3 - - - -

Detectors Set .
- 2 3 - - - -

Detectors Set .
1 2 - - - - -

The function can be used only if detector B2 is connected.

It serves to prevent excessive differences between ambient and outside temperatures.

The controller maintains constant the desired cooling temperature (ambient or discharge air) until the outside temperature exceeds the value $T^{Coo} + \Delta t$. At this point T^{Coo} is increased by 1°C for each °C increase in outside temperature.

M4.10

Summer Comp:n:NO
Diff.O.T-R.T: 6c

- Summer compen. :NO = function excluded
YES = Function enabled
- Differ. O.T - R.T : xx c = Maximum difference permitted between outside temp (O.T.) and room temp. (R.T.) or discharge air temp,

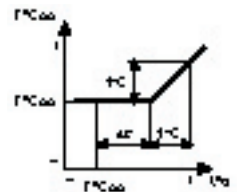

15. HUMIDITY CONTROL

M5.1

Detectors Set .
- - - - - 6 -

The control of humidity is enabled:

- if detector B6 is connected and configured;
- in the winter period;
- during the following operating modes: DAY TEMP; NIGHT TEMP; DAY FLOW T; NIGHT FLOW T.
- if fan Mv is in operation.

The controller compares the desired humidity set in **Humidity Winter 50.0%** with the humidity measured by detector B6 and, according to the difference measured and the differential set in

24.7

Humidity Winter 50.0%

27.12

Humidification Different.: 5.0%

activates the On-Off control action of the humidification unit **Mu**.

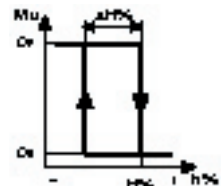

16. AUXILIARY CONTROLS

16.1 Control plant fan Mv

The plant fan Mp (output 13-14) is :

On : – with winter modes: DAY TEMP; NIGHT TEMP; DAY FLOW T; NIGHT FLOW T;

M1.3

– with winter mode FROST PROT and ambient temp. below

FrostPr. ambient
Winter 6.0c

– with summer modes: NORMAL; FLOW;

M1.3

Off : – with winter mode FROST PROT and ambient temp. above

FrostPr. ambient
Winter 6.0c

M1.6

– with all winter modes and battery temp. (B4) below

FrostP. Battery
Winter 7.0c

– with winter and summer mode: OFF

16.2 Control plant pump Mp

The plant pump Mp (output 11-12) is :

On : – with winter modes: DAY TEMP; NIGHT TEMP; DAY FLOW T; NIGHT FLOW T;

M1.3

– with winter mode FROST PROT and ambient temp. below

FrostPr. ambient
Winter 6.0c

M1.6

– with winter mode OFF and battery temp. (B4) below

FrostP. Battery
Winter 7.0c

– with summer modes: NORMAL; FLOW;

M1.3

Off : – with winter mode FROST PROT and ambient temp. above

FrostPr. ambient
Winter 6.0c

M1.6

– with winter mode OFF and battery temp. (B4) above

FrostP. Battery
Winter 7.0c

– with summer mode: OFF

16.3 Battery frost protection temperature B4

M5.1

Detectors Set .

- - - 4 - - -

The control of the battery frost protection temp. is enabled only in the winter period and only if detector B4 is connected.

When temp. measured by detector B4 is 2°C below the temperature the controller, with any winter mode running :

- switches off the fan Mv;
- switches on the plant pump Mp;
- opens the regulating valve Y.

M1.6

FrostP. Battery
Winter 7.0c

When the temp. is 2°C above the temperature set, the controller restores the operating conditions set by the mode in use.

16.4 Modifying programmes by remote control

M5.1

Detectors Set .

- - - - - 7

If the remote control R is connected and configured the operating programme in use can be modified from a distance:

For winter season:

- | | |
|----------------|---|
| 1 – OFF | = plant excluded. |
| 2 – FROSPROT | = continuous operation at desired FROSPROT Ambient temp. (Win). |
| 3 – NIGHT | = continuous operation at desired NIGHT ambient temp. (Win). |
| 4 – NORMAL | = continuous operation at desired NORMAL ambient temp. (Win). |
| 5 – AUT. + 2 C | = increase of 2°C on temperature desired by mode in use. |
| 6 – AUTOMATIC | = operation with chosen programme on controller. |

For summer season:

- | | |
|----------------|---|
| 1...3 – OFF | = plant excluded. |
| 4 – NORMAL | = continuous operation at desired Ambient temperature (Sum.). |
| 5 – AUT. – 2 C | = reduction of 2 °C of temperature required by mode in use. |
| 6 – AUTOMATIC | = operation with programme chosen on controller. |

17. SEASON SWITCHING

The controller changes its operational mode (winter heating or summer cooling) and the position of the season switch Ycs depending on which of the following is chosen:

M5.3
**Season Switching
 ALWAYS WINTER**

M5.3
**Season Switching
 ALWAYS SUMMER**

M5.3
**Season Switching
 AUT. FROM SEASONS**

- ALWAYS WINTER = control Y on Heating; season control Ycs on Winter (7-6 closed; 7-5 open).
- ALWAYS SUMMER = control Y on Cooling; season control Ycs on Summer (7-6 open; 7-5 closed).
- AUT.FROM SEASONS = switching control Y and season switch Ycs according to

season periods set

M2.18 Winter Season Fr:15.10to:15.04	M3.18 Summer Season Fr:15.06to:15.09
--	--

In this event the following conditions can occur :

– season periods cancelled:

M2.18 Winter Season Fr:----to:----	M3.18 Summer Season Fr:----to:----
--	--

Result: = control Y off; season switch Ycs in last position assumed.

– successive season periods :

M2.18 Winter Season Fr:15.10to:15.04	M3.18 Summer Season Fr:16.04to:14.10
--	--

Result; without intermediate periods

From 15.10 to 15.04 = control Y on Heating ; season switch Ycs on Winter.
 From 16.04 to 14.10 = control Y on Cooling; season switch Ycs on Summer.

– shortened season periods:

M2.18 Winter Season Fr:15.10to:15.04	M3.18 Summer Season Fr:15.05to:15.09
--	--

Result: intermediate periods with plant off:

From 15.10 to 15.04 = Y control on Heating: season switch Ycs on Winter.
 From 16.04 to 14.05 = Y control Off; season switch Ycs on Winter.
 From 15.05 to 15.09 = Y control on Cooling; season switch on Summer.
 From 16.09 to 14.10 : = Y control Off; season switch Ycs on Summer.

– overlapping season periods:

M2.18 Winter Season Fr:01.09to:15.05	M3.18 Summer Season Fr:15.03to:01.11
--	--

Result: periods overlapped in relation to outside temperature.

From 02.11 to 14.03 : = Y control on Heating; season switch Ycs on Winter.
 From 16.05 to 31.08 : = Y control on Cooling; season switch Ycs on Summer.

From 15.03 to 15.05 and from 01.09 to 01.11 :

When outside temp. remains below temp.

M1.1 Day T ambient Winter : 20.0c

 for a period longer than

M4.6 Delay Winter Season : 24hrs

 the controller switches the control Y to Heating and the season switch Ycs to Winter.

When outside temp. remains above temp.

M1.8 Day Temperature Summer : 20.0c

 for a period longer than

M4.11 Delay Summer Season : 8hrs

 the controller switches the control Y to Cooling and the switch Ycs to Summer.

M5.3
**Season Switching
 AUT. FR OUTSIDE T**

- AUT FR OUTSIDE T = switching control Y and season control Ycs according to outside temperature.

When the outside temp. remains below the temp.

M1.1 Day Temperature Winter : 20.0c

 for a period longer than

M4.6 Delay Winter Season : 24hrs

 the controller changes the control Y to Heating and the season switch Ycs to Winter.

When the outside temp. remains above the temp.

M1.8 Day T ambient Summer : 25.0c

 for a period longer than

M4.11 Delay Summer Season : 8hrs

 the controller changes the Y control to Cooling and the season control Ycs to Summer.

M5.3
**Season Switching
 FR CONTROL cs**

- Season switching in funzione della posizione del commutatore stagionale **cs (D-E1-E2)**.
 - with D-E1 closed and D-E2 open : action of outputs **Y1, Y2, Y3** and season control **Ycs** on Winter
 - with D-E1 open and D-E2 closed : action of outputs **Y1, Y2, Y3** e and season control **Ycs** on Summer

Note : The (D-E1 open; D-E2 open) adjustment may be switched off using a three-way switch (with "0" zero position).

18. PROGRAMMES & PERIODS WITH DATES

It is possible to program the operation of the plant separately for the winter season and the summer season according to use requirements:

M0.2
 Site -----
 Win: DAILY 1

For the winter period: : – WEEKLY (Win.); – DAILY 1...3 (Win.);
 – DAY TEMP (Win.); – NIGHT TEMP (Win.); – FROSTPROT;
 – DAY FLOW (Win.); – NIGHT FLOW (Win.); – OFF.

When in place of the programme there appears:
 – HOLIDAY = one of Holiday periods is running.
 – DAY T REMOTE = remote control R is in "Day" position.
 – NIGHT T REM = remote control R is in "Night" position.
 – REMOTE +2C = remote control R is in "Day" + 2°C position.
 – FROSTPROTREM = remote control R is in "Frost protection" position.
 – OFF REMOTE = remote control R is in "Off" position.

M0.4
 Site -----
 Sum: DAILY 1

For summer period: – WEEKLY (Sum); - DAILY 1...3 (Sum);
 – DAY TEMP (Sum); - DAY FLOW T (Sum); - OFF

When in place of programme there appears:
 – HOLIDAY = one of holiday periods is running.
 – DAY T REMOTE = remote control R is in "Normal" position.
 – OFF REMOTE = remote control R is in "Off" position.

18.1 Daily programmes

M2.1
 How Many Daily
 Winter Progs.? 1

Set the number of daily programmes you want to use (from 1 to 3) for the winter season and for the summer season in order to eliminate unnecessary display pages.

M3.1
 How Many Daily
 Summer Progs.? 1

In each winter daily programme (**PG1Win ... PG3Win**) and summer (**PG1Sum ... PG3Sum**) you can set a maximum of six operating periods start times (**h1...h6**) assigning to each one of the following modes:

M2.2
 P1 Win-h1 06.00
 DAY TEMP. 20.0c

For the winter season:
 – DAY TEMP 20.0c : control at temperature Ambient DAY winter (**M1.1**)
 – NIGHT TEMP 16.0c : control at temperature Ambient NIGHTwinter (**M1.2**)
 – FROST PROT 6.0c : control at temperature Ambient FROSPROTwinter (**M1.3**)
 – DAY FLOW T 20.0c : control at temperature Flow DAY winter (**M1.4**)
 – NIGHT FLOW T 16.0c : control at temperature Flow NIGHT winter (**M1.5**)
 – OFF : plant off, valve shut and pump not running.

M2.7
 P1 Win-h6 22.00
 OFF

M3.2
 P1 Sum-h1 06.00
 DAY TEMP. 25.0c

For the summer season:
 – DAY TEMP 25.0c : control with temperature Ambient summer (**M1.8**)
 – DAY FLOW 25.0c : control with temperature Flow summer (**M1.9**)
 – OFF : plant off, valve shut and pump not running.

M3.7
 P1 Sum-h1 22.00
 OFF

The period start times must be entered in increasing order.
 Unused times must be excluded by pressing at the same time the two keys + and – (– – –).
 Unused times (– – –) must not be left between programmed times.

18.2 Weekly programmes

A weekly programme is available for both the winter and the summer season.

In each weekly programme you can assign to each day of the week one of following programmes:

M2.8
 WkWin: MONDAY
 DAILY 1

For the winter season:
 – DAILY 1...3 (Win) ;
 – DAY TEMP 20.0c;
 – NIGHT TEMP 16.0c;
 – FROST PROT 6.0c;
 – DAY FLOW T 20.0c;
 – NIGHT FLOW T 16.0c;
 – OFF;

M2.14
 WkWin: SUNDAY
 DAILY 1

M3.8
 WkSum: MONDAY
 DAILY 1

For the summer season:
 – DAILY 1... 3 (Sum) ;
 – DAY TEMP 25.0c ;
 – DAY FLOW T 25.0c;
 – OFF ;

M3.14
 WkSum: SUNDAY
 DAILY 1

18.3 Holiday periods

M2.15

How Many Winter
Hol.Periods? 0

M3.15

How Many Summer
Hol.Periods ? 0

M2.16

Win.Hol.Prog.
FROSTPROT. 6.0c

M3.16

Sum.Hol.Prog.
OFF

M2.17 - M3.17

Hol.01 Start NO
Fr:--.--to:--.--

These set an operating programme, the same for all the holiday periods, that replaces the one in use. At the end of each holiday period the controller returns to its normal operation.

Enter the number of holiday periods or Bank Holidays you wish to use for the winter season (max 15) and for the summer season (max 15), in order to reduce the number of display pages dedicated to setting the dates. If left at 0 no programming pages appear.

Choose the programme to be used during all the holiday periods:

For the winter season:

- WEEKLY (Win.) ; - DAILY 1 ...3 (Win.) ;
- DAY TEMP (Win.) ; - NIGHT TEMP. (Win.) ; - FROST PROT ;
- DAY FLOW T (Win.) ; - NIGHT FLOW T (Win.) ; - OFF.

For the summer season:

- WEEKLY (Sum.) ; - DAILY 1 ...3 (Sum.) ;
- AMBIENT (Sum.) ; - FLOW (Sum.) ; - OFF.

Set the dates of each single period for the winter season and for the summer season:

- Hol 01 = selection of periods made available by
- Start : - NO = unused holiday period
 - 00 = start period at 00.00
 - 12 = start period at 12.00
- From --.-- to --.-- = day and month of start and end of holiday period.

25.15

26.15

How Many Winter
Hol.Periods ? --

How Many Summer
Hol.Periods ? --

For a single day of holiday set the same date for start and end.

To cancel holiday periods, keep pressed at the same time + and - keys.

18.4 Season periods

M2.18

Winter Season
Fr:--.--to:--.--

M3.18

Summer Season
Fr:--.--to:--.--

Define the winter and summer seasons.

Enter the day and month of the start and end of the winter season, a period in which the controller is in the heating phase.

Enter the day and month of the start and end of the summer season, period in which the controller is in the cooling phase.

To cancel the period keep pressed + and - keys at the same time.

For the use of the season periods see paragraph 12.12 Season switching.

18.5 Summer time (BST)

M2.19 - M3.19

BST
Fr:29.03to:26.10

The controller can change automatically the current time according to the BST period.

- Fr --.-- = the night of the last Saturday in March, the clock goes forward automatically one hour.
- to --.-- = the night of the last Saturday in October, the clock goes back automatically one hour.

To cancel the period, keep pressed at the same time + and - keys.

19. COMPLEMENTARY FUNCTIONS

19.1 Access keynumber

M5.9

Password Choice
- - - -

Choice and enabling of access key number which prevents the use of + and – keys and thus any modification of the data. Enter the number (1900 ... 1999) using + and – keys.
To cancel the key number, press + and – keys at the same time until the dashes reappear.

Password
- - - -

When the key number is enabled, if you press + or – keys there will appear on the display the request to enter the key number, Only after having entered in the exact key number can the + and – keys be used.

If for 15 minutes no key is pressed, the password is re-activated automatically.

19.2 Name of plant site

M5.10

Site Name
- - - - - - - -

Enter plant site name which will appear on the first page of the display.
Each dash can be replaced, using + and – keys, by a letter of the alphabet (A...Z) or by a number (0...9). The → key serves to position the cursor.

19.3 Display of measurements

M0.6

Des. Amb. T. : 20.0c
Act. Amb. T. : 20.0c

The controller displays all the measurements taken by the detectors and the data that serve to understand the operational status of the plant:

- desired ambient temp. of mode in use and actual measured by detector **B3**.

M0.7

Des. Flow t : 50.0c
Act. Flow t : 50.0c

- desired flow temp. of mode in use and actual measured by detector **B1**.

M0.8

Outside actual
Temper. : - 2.0c

- actual outside temp. Only if detector **B2** connected.

M0.9

Des. FrostP : 7.0c
Act. FrostP : 35.0c

- desired battery frost protection temp. and actual measured by detector **B4**.

M0.10

Des. Hum. 50.0%
Act. Hum. 50.0%

- desired humidity and actual measured by detector B6.

19.4 Data recording

At each change of mode and every hour the controller records a series of data indicating the operational status:

- Actual time, day of week and type of recording (change of mode or hour change).
- Current mode: On or Off; Current season: Winter or Summer.
- Values desired and calculated by controller.
- Values measured by detectors connected.
- Value of load at Y output.

The controller can memorise 14 complete recordings and the last recording brings about the cancellations of the oldest one..

If the first page is not shown on the display, the controller makes the change-of-hour recording but not the recording at the change of mode because it presumes modifications to the calibration data are in progress.

The recordings can be viewed only on the Telemangement computer.

20. ALARMIS

The alarms processed by the controller are of three types:

- alarms for operational malfunctions in the controller (LED 6.11) and in the plants controlled (LED 6.9)
- alarms for short and open detector circuits (LED 6.10)
- alarms from outside contacts (LED 6.9)

The alarm status is signalled by the LEDs on the front panel of the controller and by the word ALARM appearing on the display when the alarm is transmitted to the PC and is identified, on the configuration page, by the letter "A" alternating with the number of the alarm concerned.

With C-Bus configuration the alarms can be transmitted to a local PC and/or to the central Telemangement PC.

20.1 Functional alarms

M5.6

Funct . Alarms
- - - - 8

The functional alarms are triggered when differences persist between measured and desired values.

Except for the internal real time clock alarm (8) they do not affect the normal operation of the controller.

Factory settings: all deactivated except for internal clock alarm (8)

Using + and - keys enable the alarms of interest by replacing the dashes with numbers.

When the number flashes = alarm active.

The limit values and wait times for sending the alarms can be modified only by PC.

Type of alarm and cause:

- 1** = dtemperature difference discharge air.
 - transmitted when actual temp. less than **T°DisHea** in winter or greater than **T°DisCoo** in summer.
- 3** = temperature difference ambient (if B3 connected)
 - transmitted when actual temp. less than **T°aHea** in winter or greater than **T°aCoo** in summer.
- 4** = temperature battery frost protection (B4).
 - transmitted for frost protection when Mv Off.
- 6** = humidity difference (B6).
 - transmitted when actual humidity below **H%**.
- 8** = internal clock cannot be disabled.
 - transmitted when clock assumes meaningless values.

20.2 Detector alarms

M5.7

Detectors alarm
- - - -

The detector alarms are activated in the event of **breaks** or **short circuits** in the wiring to the detectors connected.

The effect of the alarm states is delayed by one minute.

Factory settings: all disabled.

Using + and - keys enable the required alarms by replacing the dashes with numbers.

Type of alarm and effect:

- 1** = flow detector (B1): valve stops where it is; Mv and Mp follow timed programme.
- 2** = outside detector (B2): valve stops where it is; Mv and Mp follow timed programme.
- 3** = ambient detector (B3): valve stops where it is; Mv and Mp follow timed programme.
- 4** = battery frost protection detector (B4): valve open, Mv off and Mp on.

20.3 Alarm or status of external contact (k1)

M5.8

K Alarm
-

Alarm triggered by closure of voltage-free switch **k1**, of plant components (pumps, burners, etc).

The presence of the alarm is signalled after about 60 seconds.

Factory setting: disabled.

With + key enable the required alarms by replacing the dashes with the numbers.

If not used as alarm can be used as status indicators.

21. TESTING PLANT START UP

Testing to be carried out when installation has been completed and the electric wiring and configuration carried out and checked.

M6.1

Output : VALVE
Status : IDLE

Using + and - keys choose:

- output to be tested: VALVE; PUMP; HUMID; FAN; SEAS. SWT.
- status : - with VALVE : IDLE; CLOSSES; OPENS
- with PUMP; HUMID; FAN; SEAS. SWT : ON 1; OFF.

Check the results.

22. SEQUENCE OF DISPLAY PAGES (the data and the functions are those in memory at time of delivery)

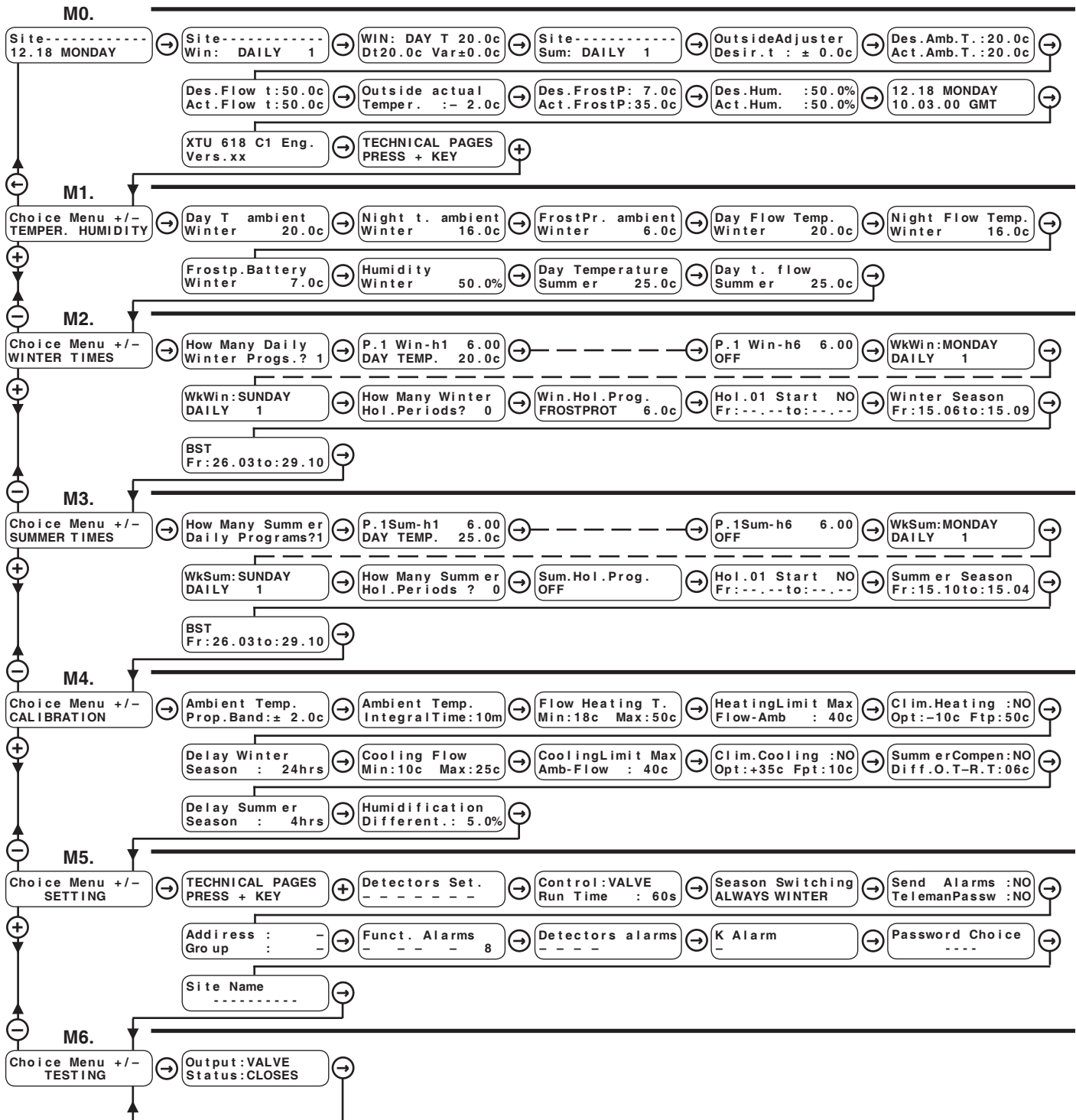

← → Keys for scrolling pages on display and positioning cursor ☒ on data that can be modified.

In the following list of display pages the data that can be modified are indicated by

By pressing these keys at the same time, or in any event after 15 minutes, the first page returns on the display Site: 12.18 MONDAY

⊖ ⊕ Keys for : - modifying the values indicated by the cursor ☒

- seeing the possible configurations of a function, for example :

Season Switching ALWAYS WINTER

or

Season Switching ALWAYS SUMMER

- passing directly from one menu (group of pages) to another.

M0. NORMAL USE				
Ref.	Display	Description	Notes	Sept.
M0.1	Site----- 12.18 MONDAY	Name site Current time and day	Set in M5.10 Set in M0.11	
M0.2	Site----- Win: DAILY 1	Choice winter programme WEEKLY; DAILY 1...3; DAY TEMP.; NIGHT TEMP.; FROST PROT. DAY FLOW T.; NIGHT FLOW T; OFF.	In Summer period page is in position M0.4 . Instead of program can appear: HOLIDAY; DAY T. REMOTE; NIGHT T. REM.; REMOTE + 2C; FROSTPROTREM; OFF REMOTE.	18.
M0.3	WIN: DAY T 20.0c Dt21.0c Var±0.0c	Winter (Win) or Summer (Sum) mode in use. Dt: Temperature desired by mode. Var : adjustment of desired temp. (max ± 9 °C)	Winter modes:DAY T20.0c; NIGHT T16.0c; DAY FLOW20.0c; NIGHTFL16.0c; FROSTPR. 6.0c; OFF. Summer modes: DAY T. 25.c; DAYFLOW T. 25.0c; OFF.	13.1
M0.4	Site----- Sum: DAILY 1	Choice summer programme: WEEKLY; DAILY 1...3; DAY TEMP; NIGHT TEMP.; OFF.	In Summer period page is in position M0.2 . Instead of programme can appear: HOLIDAY; DAY T. REMOTE; REMOTE + 2c; OFF.	18.
M0.5	Outside Adjustmer Desir.t : ± 0.0c	Temperature variation by set point adjuster	Appears if set point adjuster Rt° attached.	13.1
M0.6	Des.Amb.T.:20.0c Act.Amb.T.:20.0c	Ambient temp. desired by mode in use. Temp. measured by ambient detector B3.	Appears if B3 connected	19.3
M0.7	Des.Flow t:50.0c Act.Flow t:50.0c	Flow temp. desired by mode in use. Temp. measured by flow detector B1.	Appears if B1 connected	19.3
M0.8	Outside actual Temper. :- 2.0c	Actual outside temp. measured by B2.	Appears if B2 connected	19.3
M0.9	Des.FrostP: 7.0c Act.FrostP:35.0c	Desired battery frost protection temp. Temp. measured by frosprot detector B4.	Appears if B4 connected	19.3
M0.10	Des.Hum. :50.0% Act.Hum. :50.0%	Humidity desired by mode in use. Umidità misurata da B6.	Appears if B6 connected	19.3
M0.11	12.18 MONDAY 10.02.96 GMT	Setting: Time, Day of week & Date. Time period in use; GMT or BST.	Dates BST set in M2.19 or M3.19	
M0.12	XTU 618 Eng. Vers.xx	Identifying data of controller.		

M1. TEMPERATURES & HUMIDITY				
Ref.	Display	Description	Notes	Sept.
M1.1	Day T. ambient Winter 20.0c	Value of desired day ambient temp. for winter period.	Appears if only B3 or B1 and B3 connected	18.1
M1.2	Night t. ambient Winter 16.0c	Value of desired night ambient temp. for winter period.	Appears if only B3 or B1 and B3 connected	18.1
M1.3	FrostPr. ambient Winter 6.0c	Value of desired Frosprot ambient temp. for winter period. Only if B3 is on ambient. In Frosprot mode plant is off; when t ^a < T [°] FrPr plant is on & controlled with hysteresis of ±2°C.	Appears if only B3 or B1 and B3 connected	18.1
M1.4	Day Flow Temp. Winter 20.0c	Value of desired day flow temp. for winter period.	Appears if only B3 or B1 and B3 connected	18.1
M1.5	Night Flow Temp. Winter 16.0c	Value of desired night flow temp. for winter period.	Appears if only B3 or B1 and B3 connected	18.1
M1.6	Frostp.Battery Winter 7.0c	Value of frosprot temp. of water battery for winter period. Its intervention causes: - Fan off; - Plant pump on; - Regulating valve open.	Appears if B4 connected	16.3
M1.7	Humidity Winter 50.0%	Desired humidity value for winter period.	Appears if B6 connected	15.
M1.8	Day Temperature Summer 25.0c	Desired room temp desired for summer period.	Appears if B3 or B1 and B3 connected	18.1
M1.9	Day t. flow Summer 25.0c	Desired flow temp. for summer period.	Appears if B3 or B1 and B3 connected	18.1

M2. WINTER TIMES				
Ref.	Display	Description	Notes	Sect.
M2.1	How Many Daily Winter Progs.? 1	Choice of number of daily programmes (1...3) to be used in winter period.	Cancel the unused display pages.	18.1
M2.2	P.1 Win-h1 6.00 DAY TEMP 20.0c	Number of programme, number of time period & start time of period programmed. Choice mode to assign to period: DAY TEMP20.0c; NIGHT TEMP16.0c; FROST PROT. 6.0c; DAYFLOW T 20.0c; NIGHTFL; OFF. Other groups of 6 pages according Number in M2.1	Max. 6 periods: To cancel n unused period press + and + and – at same time - - . - - will appear. The times must be in increasing order: Do not leave - - . - - between programmed times. The modes set are the winter ones	18.1
M2.7	P.1 Win-h6 22.00 OFF			
M2.8	WkWin: MONDAY DAILY 1	Choice of winter programme for each day of the week: DAILY 1...3; DAY TEMP20.0c. FROST PROT. 6.0c; DAY FLOW T. 20.0c; NIGHT FLOW T16.0c; OFF.		18.2
M2.14	WkWin: SUNDAY DAILY 1			
M2.15	How Many Winter Hol. Periods? 0	Choice of number of holiday periods to be used (0...15) in winter period.	Cancel the unused display pages.	18.3
M2.16	Win.Hol.Prog. FROSTPROT. 6.0c	Choice of programme for all holiday periods: WEEKLY; DAILY 1...3; DAY TEMP. 20.0c; NIGHT TEMP. 16.0c; FROST PROT6.0c; DAYFLOW T.20.0c; NIGHT FLOW T16.0c; OFF.	Appears if in M2.15 number is greater than 0. Programmes set are winter ones.	18.3
M2.17	Hol.01 Start NO Fr: - - - - to: - - - -	NO=unused period; 00 = start 00 hours; 12 = start at 12.00 hours; Dates of start and end of holiday period. Other pages according figure in M2.15	Appears if in M2.15 number is greater than 0.	18.3
M2.18	Winter Season Fr: 15.10 to: 15.04	Dates of start and end of winter period.		18.4
M2.19	BST Fr: 26.03 to: 29.10	Dates of start and end of BST period.		18.5

M3. SUMMER TIMES				
Ref.	Display	Description	Notes	Sect.
M3.1	How Many Summer Daily Programs? 1	Choice of number of daily programmes (1...3) to be used in summer period.	Cancel the unused display pages.	18.1
M3.2	P.1 Sum-h1 6.00 DAY TEMP 25.0c	Number of programme, number of time period & start time of period programmed. Choice mode to assign to period: DAY TEMP25.0c ; DAY FLOW T25.0c; Other groups of 6 pages according to figure in M3.1	mMax. 6 periods: To cancel an unused period press + and – insieme, will appear - - . - -. The times must be in increasing order: Do not leave - - . - - between programmed times.	18.1
M3.7	P.1 Sum-h6 22.00 OFF			
M3.8	WkSum: MONDAY DAILY 1	Choice of summer programme for each day of the week: DAILY 1...3; DAY TEMP25.0c; DAY FLOW T. 25.0c; OFF.		18.2
M3.14	WkSum: SUNDAY DAILY 1			
M3.15	How Many Summer Hol. Periods? 0	Choice of number of holiday periods to be used (0...15) in summer period.	Cancel the unused display pages.	18.3
M3.16	Sum.Hol.Prog. OFF	Choice of programme for all holiday periods: WEEKLY; DAILY 1...3; DAY TEMP. 25.0c; DAY FLOW T.25.0c; OFF.	Appears if in M3.15 number greater than 0. Programmes set are summer ones.	18.3
M3.17	Hol.01 Start NO Fr: - - - - to: - - - -	NO= unused period; 00= start 00 hours; 12= start 12.00 hours; Dates of start and end of holiday period. Other pages according choice made in M3.15	Appears if in M3.15 number is greater than 0.	18.3
M3.18	Summer Season Fr: 15.06 to: 15.09	Dates of start and end of summer season.		18.4
M3.19	BST Fr: 26.03 to: 29.10	Dates of start and end BST,		18.5

M4. SETTING				
Ref.	Display	Description	Note	Cap.
M4.1	Ambient Temp. Prop. Band: 2.0c Flow Temperature Prop. Band: 10.0c	Heating Proportional band in \pm °C Appears if connected only B3 or B1 and B3 Appears if connected only B1	This is the base value from which the controller, using the fixed multipliers, obtains the Proportional bands of the other temperature controllers. - If only B3 connected : Pb Amb. Cooling = Pb Amb. Heating x 0.5 - If only B1 connected : Pb Flow Cooling = Pb Flow Heating x 0.5 - if B1 and B3 connected : Pb Flow Heating = Pb Amb. Heating. x 5 Pb Amb. Cooling = Pb Amb. Heating x 0.5 Pb Flow Cooling = Pb Amb. Heating x 2.5	13.2
M4.2	Ambient Temp. Integral Time: 10m Flow Temperature Integral Time: 10m	Integral time of heating and cooling in minutes	Appears if only B3 or B1 and B3 connected Appears if only B1 connected	13.2
M4.3	Flow Heating. T. Min: 18c Max: 50c	Temp. limits of heating flow. Also range of Pb room heating.	Appears if B1 and B3 connected	13.4
M4.4	Heating Limit Max Flow-Amb : 40c	Limit temp. of flow given by maximum difference between flow and room temp. to avoid air stratification.	Appears if B1 and B3 connected	13.4
M4.5	Clim. Heating : NO Opt: -10c Ftp: 50c	Weather variation of winter flow Opt = Design outside temp. Ftp = Design flow temp.	Appears if only detectors B1 and B2 connected and detector B3 is not connected.	14.1
M4.6	Delay Winter Season : 24hrs	Time for which outside temp. must remain below winter day room temp. (if B3 connected) or below winter normal Flow temp. (if only B1 connected) before switching to winter.	Appears only if M5.3 is AUT.FR.OUTSIDE T	17.
M4.7	Cooling Flow Min: 10c Max: 25c	Limits of cooling discharge air temp. Is also range of Pb room cooling,	Appears if B1 and B3 connected	13.4
M4.8	Cooling Limit Max Amb-Flow : 40c	Limits of flow temp. given by difference temp. between ambient and flow temperatures to avoid condensation in flow duct.	Appears if B1 and B3 connected	13.4
M4.9	Clim. Cooling : NO Opt: 35c Fpt: 10c	Compensation for summer flow temp. Opt = Design outside temp. Fpt = Design flow temp.	Appears if B1 and B2 connected and B3 not connected	14.1
M4.10	Summer Compen: NO Diff. O.T-R.T: 6c	Summer compensation : NO ; YES. Diff. O.T.-R.T = maximum difference temp. allowed between summer outside temp. and desired temp. (flow or room) above which the desired temp. is increased by 1°C for each °C increase in outside temp.	Appears if B2 connected	14.1
M4.11	Delay Summer Season : 4hrs	Time which outside temp. must remain above summer DAY Ambient temp. (if B3 connected) or above summer DAY flow temp. (if only B1 connected) before switching to summer.	Appears only if M5.3 is AUT.FR.OUTSIDE T	17.
M4.12	Humidification Different. : 5.0%	Humidification differential in %.	Appears only if B6 connected	15.

M5. CONFIGURATION CONTROLLER				
Ref.	Display	Description	Notes	Sect.
M5.1		Configuration detectors connected (inputs B-M). - = detector not connected; number = detector connected Warning. If the configuration of the detectors is changed the timed programme reverts to the default data.	1 : Discharge air temp. detector B1 . 2 : Outside temp. detector B2 . 3 : Ambient or extract air detector temp. detector B3 . 4 : Frost protection temp. detector B4 . 5 : Desired temp. set point adjuster Rt° . 6 : Humidity detector B6 . 7 : Remote programme selector R .	12.
M5.2		Choice type of control : VALVE ; ON-OFF ; Total valve actuator run time; appears only if VALVE.	VALVE = 3-wire modulating control ON-OFF = On-Off control in 1 or 2 stages	13.3.4
M5.3		Choice type of season switching: ALWAYS WINTER; ALWAYS SUMMER; AUT.FROM SEASONS; AUT. FR. OUTSIDE T; FR.CONTROL cs.	By selecting "FR CONTROL cs", the (D-E1 open; D-E2 open) adjustment may be switched off using a three-way switch (with "0" zero position).	17.
M5.4		Enabling alarms to send to Telemangement PC. Enabling Telemangement password	Only if connected in C-Bus	10.4
M5.5		Telematic address of controller. Group to which controller assigned.	Only if connected in C-Bus	10.3
M5.6		Enabling functional alarms. Factory setting: enabled only 8 (cannot be disabled).	1 : Discharge air temp. alarm B1 3 : Ambient or extract air temp. alarm B3 . 4 : Frost protection temp. alarm B4 . 6 : Humidity alarm B6 . 8 : Internal clock alarm.	20.1
M5.7		Enabling alarms for short or open circuit to detectors.	1 : Discharge air detector B1 . 2 : Outside detector B2 . 3 : Ambient or extract air detector B3 . 4 : Frost protection detector B4 .	20.2
M5.8		Enabling On-Off alarm. Factory setting : disabled	1 : Input E1; alarm with k1 closed.	20.3
M5.9		Choice keynumber for preventing use + and - keys (1901 ... 1999).	To cancel keynumber press + and - keys together	19.1
M5.10		Entering plant site name.	Use + and - keys to enter letters or numbers. Use ← and → keys to change position.	19.2
M6. TESTING				
Rif.	Display	Description	Notes	Sect.
M6.1		Choice outputs to be tested Choice output status.	Choice output: VALVE; PUMP; HUMID.; FAN; SEAS.SWT. Choice status: With VALVE: IDLE; CLOSES; OPENS. With PUMP, HUMID., FAN, SEAS.SWT: ON; OFF.	21.

Modifiche scheda

Date	Revision No.	Page	Section	Amendment description	Firmware version	Software version
14.12.10 VM	01	11 20	17. Season switching M5 Configuration control	Clarification on the use of season switch "FR CONTROL cs"		